



# SOLUTIONS

for Refineries



# KLINGER GROUP

Visionary by Tradition



KLINGER is the world's leading manufacturer and provider of sealing and fluid control solutions.

Founded in 1886 as a family enterprise, the pioneer in gasket technology today has evolved into a globally operating corporate group comprising independent global manufacturing, sales and service companies that offer unique know-how and expert on-site consulting services in 60 countries around the world.

Our customers include leading companies from a wide range of industries from manufacturing, infrastructure and automotive to marine, oil & gas, chemicals, pulp & paper, as well as energy, food & beverage, and pharmaceuticals. KLINGER employs around 2,800 people worldwide with total annual sales of around 684 million euros.

€ **684 MIO. ANNUAL SALES**  
684 million euros in revenue generated by the KLINGER Group per year.

 **2,800 EMPLOYEES**  
Our global workforce is 2,800 people strong.

 **80 MARKETS**  
KLINGER Group has already exported to 80 countries and counting.

 **18 PRODUCTION SITES**  
The KLINGER Group manufactures gaskets, valves, instrumentation, expansion joints and hoses in almost 20 countries.

 **60 COUNTRIES**  
The KLINGER Group subsidiaries and representatives are at home all over the world.



In a conventional refinery, crude oil is transformed and refined into higher-value products like gasoline, diesel, kerosene, heating oil and LPG. Also, feedstock for the petrochemical industry like naphtha is produced in the refinery. The production of the different components can be split into three general processes:

- » Fractionation process – the distillation of the crude into the different components in the distillation columns
- » Conversion process – the dividing, unification and alteration of the hydrocarbons in the cracking, alkylation and reforming units
- » Treatment process – to remove impurities and undesirable contaminants

### VACUUM DISTILLATION

The heavy components of crude oil distillation cannot be separated because the high temperature needed would start thermal cracking. That's why these components are going directly to vacuum distillation. The vacuum in the column lowers the boiling point of the components and allows additional separation at the same temperature in the column.

### DELAYED COKING

Delayed coking is a thermal cracking process in which the feed is heated up to cracking temperature and pumped into the coke drum where the cracking takes place. The gaseous components are removed and enter the fractionator, where they are separated according to their different boiling points. Over time the drum fills with porous coke. Once the drum is filled, the feed changes to the second drum. The coke in the first drum is treated with steam, then cooled with water, and finally cut up with a high pressure water jet before being removed from the drum.

### ALKYLATION

In the alkylation unit two low molecular weight hydrocarbons are converted into a heavier hydrocarbon with a high octane number. There are two different processes depending on the acid used, sulfuric acid alkylation and the hydrofluoric acid alkylation process. Thanks to the strong acids, the reaction takes place at low temperature and low pressure. In both processes the acid is used to start a chemical reaction that converts isobutane and propene or butene to liquid alkylate.

### ATMOSPHERIC DISTILLATION

The crude distillation unit is the first stage in processing crude oil in a refinery, which physically separates the hydrocarbons found in the oil according to their boiling point. The crude oil is heated to about 400 °C and enters the distillation column. In the distillation column there is a temperature gradient with high temperature at the bottom and low temperature at the top. The vaporized components of the crude oil rise in the column and condense at different heights depending on the condensation temperature of each component, while the heavy components remain at the bottom.

### HYDROCRACKING

In the hydrocracker, heavy hydrocarbons are transformed with the help of H<sub>2</sub> and a catalyst into lighter hydrocarbons. The process requires high temperatures and high pressure for the needed cracking and hydrogenating reactions.

### FLUID CATALYTIC CRACKING (FCC)

FCC is a catalytic cracking process. The feedstock is injected into the process. The hot catalyst vaporizes and cracks the heavy hydrocarbons into lighter components. These lighter components are removed from the catalyst in the reactor and later separated in a distillation column. During the process a large amount of coke is produced and deposited on the catalyst surface. This deactivates the catalyst. The coke deposit is burned off in the regenerator and the catalyst reenters the process.

### HYDROTREATING

Hydrotreating is used to remove sulfur from the refinery streams with the help of hydrogen and a catalyst. This process is necessary to lower the SO<sub>2</sub> emission of the end products and to ensure that the sulfur is not contaminating the catalysts of the downstream processes.

### VISBREAKING

Visbreaking is a thermal process to crack the large hydrocarbon molecules and reduce the viscosity of the feed. The process is non-catalytic. There are two varieties of the process. Soaker visbreaking and coil visbreaking. Soaker visbreaking involves the feedstock being heated up in a furnace. The cracking process takes place in the soaker and can take several minutes. In coil visbreaking the temperature is higher and the cracking takes place in or right downstream of the furnace.

# BIOFUEL UNITS HVO

## Green Production Process

In the biofuel units, fuels with CO<sub>2</sub>-savings potentials of up to 90% are produced. In a catalytic reaction, hydrotreated vegetable oil (HVO) or sustainable aviation fuel (SAF) are produced from vegetable oils or animal fats. Particularly interesting is that used oils or waste can also be used in this process. Since the processes are similar to conventional

refinery processes, the systems can be fully integrated into existing refineries. Due to the high compatibility with fossil diesel, HVO can be mixed with fossil diesel in any percentage or used in its pure form as a diesel substitute. HVO can be upgraded to SAF through an isomerization process.

### HYDROGEN PRODUCTION

The production of hydrogen in a biorefinery is carried out through water electrolysis. This process allows producing hydrogen without generating CO<sub>2</sub> emissions using electricity from renewable sources. (green hydrogen)

### HYDROTREATING

In the hydrotreating reactor, the feedstock is mixed with hydrogen. Under high pressure and moderate temperature, unsaturated fatty acids are converted into saturated hydrocarbons with the help of a metallic catalyst. In the same process, oxygen, sulfur and nitrogen are reduced, which results in an improvement in the final product. This can be followed by an isomerization process to adjust the hydrocarbons. Finally, the individual products are separated and stored.

### RENEWABLE ENERGY

Renewable energy from sources like wind, solar or water are used for the transformation into various intermediate and end products. Biomass power plants are also of interest for generating heat and energy for the refinery.

### STORAGE

The raw material, mostly vegetable oils, waste oils or animal fats, is delivered and stored in the tank farm. For later use, it is filtered, dewatered and, depending on the raw material, the various impurities are removed.



# VALVES

## GATE VALVES

Gate valves offer safe and reliable shutoff solutions in any aboveground, underground or subsea application, including in critical environments.

Designed and manufactured in accordance with API 6D, 6DSS, 6A and 17D standards, our gate valves are available in a variety of configurations to meet specific customer needs and application parameters.



### BELLOWS SEAL GATE VALVE

#### BENEFITS / PROPERTIES

Bellows seal gate valve; welded bonnet with rising exterior stem and yoke – fixed handwheel; solid one-piece wedge; face-to-face dimensions as per manufacturer standard; full bore; construction according to API 602 & ASME B16.34 in current versions.

#### SPECIFICATIONS

- » Connections: ASME B16.25 B.W., ASME B16.11 S.W.
- » API 602 standard class
- » Size: 1/2" – 1 1/2"
- » Rating: 800 lbs
- » Material: stainless steel
- » Trim: 10



### FORGED LOW-PRESSURE GATE VALVE

#### BENEFITS / PROPERTIES

Gate valve, raised face flanges (R.F.); bolted bonnet, exterior screw with rising stem and yoke – fixed handwheel; flexible or solid one-piece wedge; ASME B16.10 face-to-face dimensions; design, testing and construction according to API 602 & ASME B16.34 in current versions.

#### SPECIFICATIONS

- » Connections: flange ASME B16.5, R.F. – ASME B16.34 standard class
- » Size: 1/2" – 1 1/2"
- » Rating: 150 – 300 lbs
- » Material: carbon-steel, stainless steel, alloy steel
- » Trim: 5, 8, 10, 12



### FORGED HIGH-PRESSURE GATE VALVE

#### BENEFITS / PROPERTIES

Gate valve; bolted/welded bonnet, exterior screw with rising stem and yoke – fixed handwheel; flexible or solid one-piece wedge; face-to-face dimensions as per manufacturer standard; design, testing and construction according to API 602 & ASME B16.34 in current versions.

#### SPECIFICATIONS

- » Connections: ASME B16.25 B.W., ASME B16.11 S.W., ASME B1.20.1 threaded female, flange ASME B16.5, R.F., ASME B16.11 socket weld one end / ASME B1.20.1 threaded female other end – API 602 standard class
- » Size: 1/2" – 1 1/2"
- » Rating: 600 – 2,600 lbs
- » Material: carbon-steel, stainless steel, alloy steel, duplex, super duplex
- » Trim: 3, 5, 8, 9, 10, 12, 17, duplex, super duplex, 317L



### CAST LOW-PRESSURE GATE VALVE

#### BENEFITS / PROPERTIES

Gate valve; bolted bonnet with rising stem, exterior screw and yoke – fixed handwheel; ASME B16.10 face-to-face dimensions; design, construction and testing according to API 600 & ASME B16.34 in current versions.

#### SPECIFICATIONS

- » Connections: flange ASME B16.5, R.F./RTJ-ASME B16.34 standard class for Ø 24" and smaller
- » ASME B16.47 Series B, R.F./RTJ-ASME B16.34 standard class for Ø 26" and larger
- » ASME B16.25 B W-ASME B16.34 standard class
- » Size: 2" – 42"
- » Rating: 150 – 300 lbs
- » Material: carbon-steel, stainless steel, alloy steel, Inconel, Monel, super duplex
- » Trim: 3, 5, 8, 9, 10, 12, 13, 16, 17, 19, super duplex, 317L
- » Wedge options: one-piece, flexible one-piece, split, parallel double-disc



### CAST HIGH-PRESSURE GATE VALVE

#### BENEFITS / PROPERTIES

Gate valve; rising exterior stem and yoke – fixed handwheel; flexible one-piece wedge/one-piece wedge; ASME B16.10 face-to-face dimensions; construction according to API 600 & ASME B16.34 in current versions.

#### SPECIFICATIONS

- » Connections: flange ASME B16.5, R.F./RTJ-ASME B16.34 standard class for Ø 24" and smaller
- » ASME B16.25 B W-ASME B16.34 standard class
- » Size: 2" – 24"
- » Rating: 600 – 2,500 lbs
- » Material: carbon-steel, stainless steel, alloy steel
- » Trim: 5, 8, 9, 10, 16, 17, 317L
- » Bonnet options: bolted, welded and pressure seal



### VALVOLET GATE VALVE

#### BENEFITS / PROPERTIES

Gate valve with extended body; integrally reinforced one end and socket weld the other end (VALVOLET/SW); welded bonnet with rising exterior stem and yoke – fixed handwheel; flexible or solid one-piece wedge; face-to-face dimensions as per manufacturer standard; construction according to API 602 & ASME B16.34 in current versions.

#### SPECIFICATIONS

- » Connections: extended and integrally reinforced one end (Valvolet) and ASME B16.11 S.W. other end – API 602 & ASME B16.34 standard class
- » Size: 1/2" – 1 1/2"
- » Rating: 800 – 1,500 lbs
- » Material: carbon-steel, stainless steel, alloy steel
- » Trim: 5, 8, 9, 10, 317L

# VALVES

## GLOBE VALVES

Globe valves can handle a variety of fluids in liquid or gaseous phase, provide a tight seal and precise flow regulation.

The wide variety of body and trim materials makes them suitable for everything from standard to highly demanding applications.

Our valves are designed according to API 602 or BS1873 for forged valves and API 623 for cast valves.



### FORGED HIGH-PRESSURE GLOBE VALVE

#### BENEFITS / PROPERTIES

Globe valve; bolted or welded bonnet with rising exterior stem and yoke – fixed or rising handwheel; obturator type conical; face-to-face dimensions as per manufacturer standard; conventional pattern; standard or full bore; construction according to API 602 & ASME B16.34 in current versions.

#### SPECIFICATIONS

- » Connections: flange ASME B16.5, R.F. – ASME B16.34 standard class
- » ASME B16.25 B W – ASME B16.34 standard class
- » ASME B1.20.1 threaded female – API 602 & ASME B16.34 standard class
- » Size: 1/2" – 1 1/2"
- » Rating: 600 – 1,500 lbs



### CAST LOW-PRESSURE GLOBE VALVE

#### BENEFITS / PROPERTIES

Globe valve; bolted bonnet with exterior screw and yoke; conventional pattern; ASME B16.10 face-to-face dimensions; construction according to API 623 or BS 1873 & ASME B16.34 in current versions.

#### SPECIFICATIONS

- » Connections: flange ASME B16.5, R.F./RTJ – ASME B16.34 standard class for Ø 24" and smaller
- » ASME B16.25 B W – ASME B16.34 standard class
- » Size: 2" – 24"
- » Rating: 150 – 300 lbs
- » Material: carbon-steel, stainless steel, alloy steel, duplex, super duplex



### CAST HIGH-PRESSURE GLOBE VALVE

#### BENEFITS / PROPERTIES

Globe valve; bolted bonnet with exterior screw and yoke; conventional pattern; ASME B16.10 face-to-face dimensions; construction according to API 623 or BS 1873 & ASME B16.34 in current versions.

#### SPECIFICATIONS

- » Connections: flange ASME B16.5, R.F./RTJ – ASME B16.34 standard class for Ø 24" and smaller
- » ASME B16.25 B W – ASME B16.34 standard class
- » Size: 2" – 24"
- » Rating: 600 – 2,500 lbs
- » Material: carbon-steel, stainless steel, alloy steel



### BELLOWS SEAL GLOBE VALVE

#### BENEFITS / PROPERTIES

Globe valve; bellows seal bolted bonnet with exterior stem and yoke – rising handwheel; obturator type: ball or conical; conventional pattern, ASME B16.10 face-to-face dimensions; construction according to API 623 or BS 1873 & ASME B16.34 in current versions.

#### SPECIFICATIONS

- » Connections: flange ASME B16.5, R.F. – ASME B16.34 standard class
- » Size: 2" – 24"
- » Rating: 150 – 300 lbs
- » Material: stainless steel
- » Trim: 16



### FORGED LOW-PRESSURE GLOBE VALVE

#### BENEFITS / PROPERTIES

Globe valve; bolted or welded bonnet with rising exterior stem and yoke – fixed or rising handwheel; obturator type: conical; face-to-face dimensions as per manufacturer standard; conventional pattern; standard or full bore; construction according to API 602 & ASME B16.34 in current versions.

#### SPECIFICATIONS

- » Connections: flange ASME B16.5, R.F. – ASME B16.34 standard class
- » ASME B16.25 B W – ASME B16.34 standard class
- » ASME B1.20.1 threaded female – API 602 & ASME B16.34 standard class
- » Size: 1/2" – 1 1/2"
- » Rating: 150 – 300 lbs



### HIGH-PRESSURE GLOBE VALVE Y-PATTERN

#### BENEFITS / PROPERTIES

Globe valve; exterior screw with rising stem and yoke – fixed handwheel; conical plug or ball-type disc; "Y" pattern; face-to-face dimensions as per manufacturer standard; design, testing and construction according to ASME B16.34 in current version.

#### SPECIFICATIONS

- » Connections: ASME B16.25 B W – ASME B16.34 standard class
- » Size: 1/2" – 24"
- » Rating: 1,500 – 2,500 lbs
- » Material: carbon-steel, stainless steel, alloy steel, Inconel
- » Trim: 5, 17, 19C

# VALVES

## CHECK VALVES

Check or non-return valves are uni-directional sensing valves, which automatically prevent the backflow of the media.

Check valves are available in various types depending on the requirements of the application.

The valves are designed, manufactured and tested in accordance with API 594, API 602 and B16.34 standards.

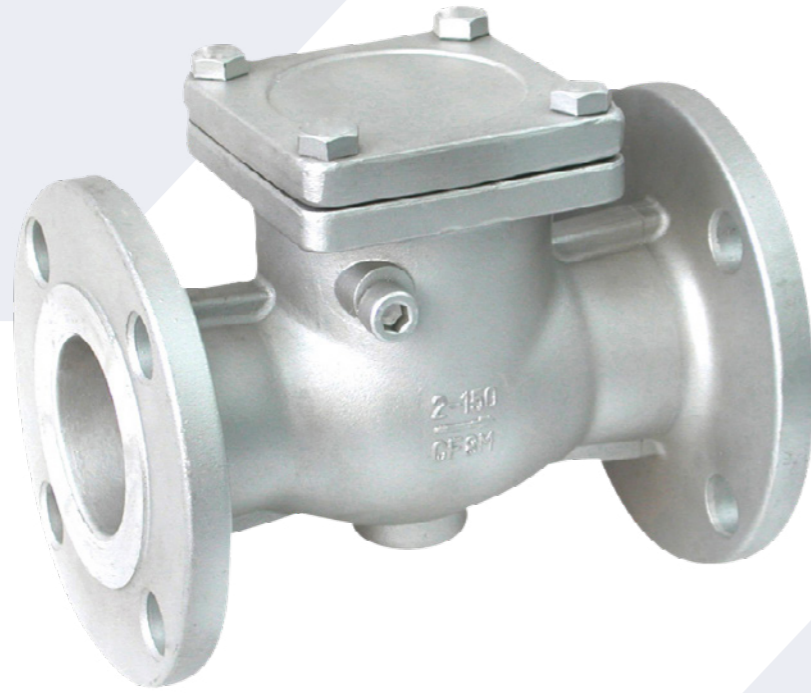

### STOP CHECK VALVE

#### BENEFITS / PROPERTIES

Stop-check valve, right angle or "Y" pattern; conical plug or ball-type disc; bolted, welded or pressure seal bonnet – rising or fixed handwheel; ASME B16.10 face-to-face dimensions; construction according to API 623/API 602 or BS 1873 & ASME B16.34 in current versions.

#### SPECIFICATIONS

- » Connections: ASME B16.25 B.W. – ASME B16.34 standard class
- » Size: 1/2" – 24"
- » Rating: 600 – 1,500 lbs
- » Material: carbon-steel, alloy steel
- » Trim: 5, 16
- » Option: spring-loaded disc

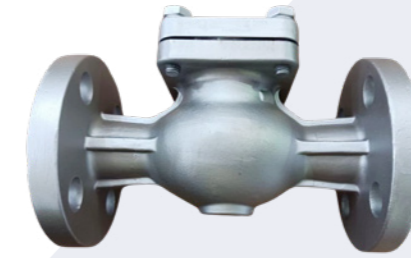

### SWING CHECK VALVE

#### BENEFITS / PROPERTIES

Swing check valve; pressure seal, bolted or welded cap; ASME B16.10 face-to-face dimensions; design, construction and testing according to API 594 or BS 1868 & ASME B16.34 in current versions.

#### SPECIFICATIONS

- » Connections: flange ASME B16.5, R.F./RTJ – ASME B16.34 standard class for Ø 24" and smaller
- » ASME B16.47 Series B, R.F./RTJ – ASME B16.34 standard class for Ø 26" and larger
- » ASME B16.25 B W – ASME B16.34 standard class
- » Size: 2" – 48"
- » Rating: 150 – 2,500 lbs
- » Material: carbon-steel, stainless steel, alloy steel, duplex, super duplex
- » Trim: 5, 8, 9, 10, 12, 16, 17, 317L, duplex, super duplex, 321/347, 316L + ST6, bronze
- » Option: obturator

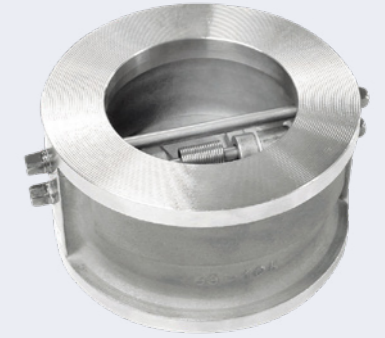

### DUAL-PLATE CHECK VALVE

#### BENEFITS / PROPERTIES

Lug body check valve, mounting between raised face flanges (RF); dual plate; design, testing and construction according to API 594 or BS 1868 & ASME B16.34 in current versions.

#### SPECIFICATIONS

- » Connections: ASME B16.5, R.F. – ASME B16.34 standard class for Ø 24" and smaller
- » ASME B16.47 Series B, R.F. – ASME B16.34 standard class for Ø 26" and larger
- » Size: 2" – 48"
- » Rating: 150 – 600 lbs
- » Material: carbon-steel, alloy steel
- » Trim: 5, 10



### FORGED CHECK VALVE

#### BENEFITS / PROPERTIES

Check valve; bolted or welded bonnet; straight pattern; face-to-face dimensions as per ASME B16.10 (BW + flange) or manufacturer standard (SW, F-THRD); design, testing and construction according to API 602 & ASME B16.34 as amended.

#### SPECIFICATIONS

- » Connections: flange ASME B16.5, R.F. – ASME B16.34 standard class
- » ASME B16.25 B W – ASME B16.34 standard class
- » ASME B16.11 S.W or ASME B1.20.1 threaded female – API 602 & ASME B16.34 standard class
- » Size: 1/2" – 1 1/2"
- » Rating: 300 – 2,500 lbs
- » Material: carbon-steel, stainless steel, alloy steel, duplex, super duplex
- » Trim: 5, 8, 9, 10, 12, 16, 17, 317L, duplex, super duplex
- » Obturator type: ball, piston, swing disc



### TILTING DISC CHECK VALVE

#### BENEFITS / PROPERTIES

Tilting disc check valve; straight or inclined seat disc; pressure seal, bolted cap; ASME B16.10 face-to-face dimensions; design, testing and construction according to API 594 or BS 1868 & ASME B16.34 as amended.

#### SPECIFICATIONS

- » Connections: ASME B16.25 B W – ASME B16.34 standard class
- » Size: 2" – 12"
- » Rating: 1,500 lbs
- » Material: stainless steel
- » Trim: 17



### LIFT CHECK VALVE

#### BENEFITS / PROPERTIES

Lift check valve with raised-face flanged ends (RF) type, guided piston with spring horizontal pattern; bolted bonnet; ASME B16.10 face-to-face dimensions; design, testing and construction according to BS 1868 or API 6D & ASME B16.34 as amended.

#### SPECIFICATIONS

- » Connections: flange ASME B16.5, R.F. – ASME B16.34 standard class
- » Size: 2" – 48"
- » Rating: 150 – 600 lbs
- » Material: carbon-steel, stainless steel
- » Trim: 8, 10, 321/347
- » Obturator type: piston

## BALL VALVES

Due to their main properties, ball valves are highly versatile for fluid handling and among the most popular valves found in the industry. Ball valves feature a quick closing 1/4 turn, which is usually effected by means of a lever, thus enabling simple operation.

Our industrial ball valves are important components in process engineering systems of all important industries for maintenance operations in transport and production processes.

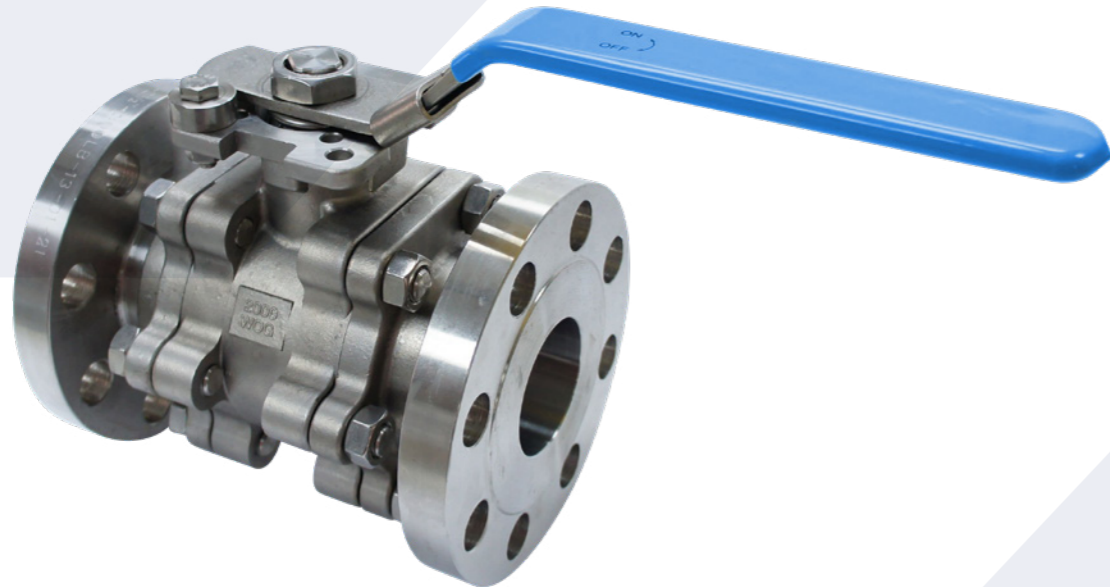

### ONE-PIECE BALL VALVE

#### BENEFITS / PROPERTIES

Ball valve; floating ball one-piece body, end entry; single reduced bore; fire-safe & anti-static device; design, testing and construction according to API 608 or EN-ISO 17292 & ASME B16.34 in current versions.

#### SPECIFICATIONS

- » Connections: ASME B16.5, R.F. – ASME B16.34 standard class
- » ASME B16.11 S.W.; – API 602 & ASME B16.34 standard class
- » Size: 1/2" – 24"
- » Rating: 150 – 800 lbs
- » Material: carbon-steel
- » Trim: 10, ASTM B564 UNS: N04400 or ASTM B164 UNS: N04400
- » Option: body extended by means of nipples on the ends, fully jacketed valve



### TWO-PIECE FLOATING BALL VALVE

#### BENEFITS / PROPERTIES

Ball valve, floating ball valve, two-piece body; face-to-face dimensions as per ASME B16.10 – short or long pattern; design, testing and construction according to API 608 or BS 5351/ EN-ISO 17292 & ASME B16.34 in current versions; fire-safe & anti-static device

#### SPECIFICATIONS

- » Connections: ASME B16.5, R.F. – ASME B16.34 standard class
- » Size: 1/2" – 24"
- » Rating: 150 – 300 lbs
- » Material: carbon-steel, stainless steel
- » Trim: 10, 13, ASTM A-105 + ENP; ASTM A351 Gr. CF8M, ASTM A182 Gr. F316
- » Option: reduced or full bore



### TWO-PIECE TRUNNION BALL VALVE

#### BENEFITS / PROPERTIES

Ball valve, trunnion-mounted ball valve, two-piece body; face-to-face dimensions as per ASME B16.10 – short or long pattern; construction according to API 608 or BS 5351/EN-ISO 17292 & ASME B16.34 in current versions; fire-safe & anti-static device.

#### SPECIFICATIONS

- » Connections: ASME B16.5, R.F. – ASME B16.34 standard class
- » Size: 1/2" – 24"
- » Rating: 150 – 600 lbs
- » Material: carbon-steel, stainless steel
- » Trim: 5, 317 + ST6, ASTM B564 UNS: N04400, ASTM A494 Gr. M35-1
- » Option: reduced or full bore



### THREE-PIECE BALL VALVE

#### BENEFITS / PROPERTIES

Ball valve; floating ball, three-piece body; face-to-face dimensions according to manufacturer standard; full or reduced bore; fire-safe & anti-static device; design, testing and construction according to API 608 or EN-ISO 17292 & ASME B16.34 in current versions.

#### SPECIFICATIONS

- » Connections: ASME B16.11 SW – API 608 & ASME B16.34 standard class
- » ASME B1.20.1 threaded female – API 602 & ASME B16.34
- » Size: 1/2" – 2"
- » Rating: 800 lbs
- » Material: carbon-steel, stainless steel
- » Trim: 10, ASTM A351 Gr. CF8M, ASTM A182 Gr. F316, ASTM B564 UNS: N04400
- » Option: body extended by means of nipples on the ends



### TOP-ENTRY BALL VALVE

#### BENEFITS / PROPERTIES

Trunnion ball valve, top entry, extended bonnet for high temperature; face-to-face dimensions as per ASME B16.10 – long pattern; single reduced bore; design, testing and construction according to API 608 or BS 5351/EN-ISO 17292 & ASME B16.34 in current versions; fire-safe & anti-static device.

#### SPECIFICATIONS

- » Connections: ASME B16.5, R.F. – ASME B16.34 standard class
- » Size: 1/2" – 24"
- » Rating: 600 lbs
- » Material: carbon-steel
- » Trim: solid Stellite 6



## BALL VALVES BALLOSTAR KHA/KHI

The modular design of the small and medium-sized three-piece KHA ball valves offers a wide range of styles. Three kinds of connections, nine types of sealing elements and nine stuffing box designs ensure that Ballostar KHA ball valves are suitable for many different operating conditions and applications.

The Ballostar KHI ball valves in larger nominal sizes are designed to meet even the most stringent requirements. One of the unique features of Ballostar KHI is its sealing system, which ensures exceptional performance. The ball valve housing is also available with a test and drain valve, which enables the pressure to be relieved without having to open the pipeline when the ball is closed.

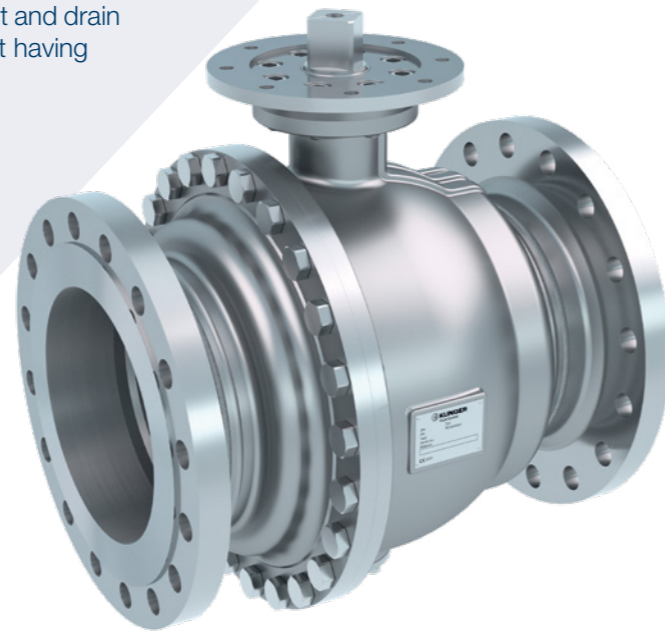

### FIRE SAFETY

Ball valves can be used for fire-safe applications at any given time as the basic design is already certified per default.

### DOUBLE BLOCK & BLEED

With the DBB function you only need one Ballostar KHA/KHI ball valve instead of two separate valves.

This alternative solution not only saves time and money, but is especially useful for installations with limited space, TA-LUFT (VDI 2440).

The Ballostar KHA/KHI valve remains significantly below the prescribed emission limits for keeping the air clean.

### OXYGEN DESIGN

Due to the fact that increased concentrations of oxygen lead to greater fire and explosion hazards, a valve must also meet certain prerequisites regarding oxygen.



### FLOATING BALL VALVE INTEC K200

#### BENEFITS / PROPERTIES

2-piece high-end floating ball valves with proven design and perfect technical functionality for safe shutoff. The ball valves are available in various material combinations and with different features.

#### SPECIFICATIONS

- » Connections: ASME B16.5, R.F. – ASME B16.34 standard class
- » Size: 1/2" – 8"
- » Rating: 150 – 300 lbs
- » Soft seats, fixed seat rings on both ends
- » Available in stainless steel and carbon-steel
- » Special materials optionally available
- » Fire-safe
- » Leakage rate A
- » Stuffing box system fully resistant to aging and fugitive emissions
- » Certified in accordance with "TA-Luft" and ISO 15848
- » Options: INTEC K220 spring-loaded seat rings on one end specifically for temperature and pressure changes
- » INTEC K221 with metal seats

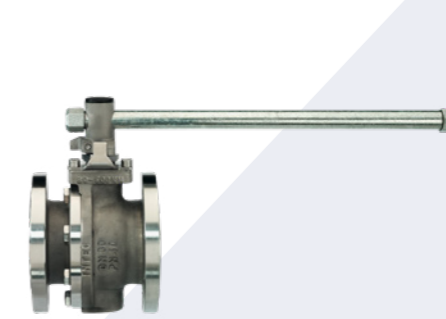

### TRUNNION MOUNTED BALL VALVE INTEC K211

#### BENEFITS / PROPERTIES

2-piece trunnion-mounted ball valves with spring-loaded seat rings on both ends. Trunnion-mounted ball valves are effective in both low- and high-pressure situations. In low- or no-pressure situations, the spring-loaded seats create a seal. The valve also is suitable for high-pressure applications.

#### SPECIFICATIONS

- » Connections: ASME B16.5, R.F. – ASME B16.34 standard class
- » Size: 1/2" – 20"
- » Rating: 150 – 2,500 lbs
- » Soft and metal seats
- » Up to +800 °C (metal seat)
- » Spring-loaded seat rings on both ends
- » Available in stainless steel and carbon-steel
- » Special materials optionally available
- » Cryogenic version (down to -196 °C)
- » Wide range of sealing materials
- » Fire-safe
- » Leakage rate A
- » Stuffing box system fully resistant to aging and fugitive emissions
- » Certified in accordance with "TA-Luft" and ISO 15848

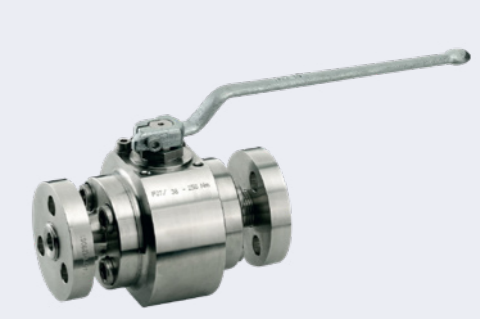

### HIGH PRESSURE BALL VALVE INTEC K811

#### BENEFITS / PROPERTIES

3-piece high-pressure ball valve of the modular INTEC system technology. High-precision bearings and spring-loaded seat ring elements on both ends ensure safe handling in all applications in the high-pressure range.

#### SPECIFICATIONS

- » Connections: ASME B16.5, R.F. – ASME B16.34 standard class
- » Size: 1/2" – 8"
- » Rating: 150 – 4,500 lbs
- » Soft and metal seats
- » Up to +800 °C (with metal seat)
- » Spring-loaded seat rings on both ends
- » Available in stainless steel and carbon-steel
- » Special materials optionally available
- » Cryogenic version (down to -196 °C)
- » Wide range of sealing materials
- » Fire-safe
- » Leakage rate A
- » Stuffing box system fully resistant to aging and fugitive emissions
- » Certified in accordance with "TA-Luft" and ISO 15848



## PLUG VALVE

### BENEFITS / PROPERTIES

Plug valve; non-lubricated – two-way; short pattern; face-to-face dimensions according to ASME B16.10; design external leakage, fire-safe & anti-static device; design, testing and construction according to API 599 or BS 5353 & ASME B16.34 in current versions.

### SPECIFICATIONS

- » Connections: flange ASME B16.5, R.F. – ASME B16.34 standard class
- » Size: 1/2" – 12"
- » Rating: 150 lbs
- » Material: carbon-steel
- » Trim: ASTM A351 Gr. CF8M or ASTM A182 Gr. F316



## LUBRICATED PLUG VALVE

### BENEFITS / PROPERTIES

Lubricated plug valve; bolted bonnet; taper-plug, pressure-balanced type; ASME B16.10 – short or regular pattern; face-to-face dimensions; reduced bore; design, testing and construction according to BS 5353 or API 599 & ASME B16.34 in current versions.

### SPECIFICATIONS

- » Connections: flange ASME B16.5, R.F. – ASME B16.34 standard class; ASME B16.11 SW – ASME B16.34 standard class; ASME B1.20.1 threaded female – API 602 & ASME B16.34 standard class
- » Size: 1/2" – 12"
- » Rating: 150 – 1,500 lbs
- » Material: carbon-steel
- » Trim: N° 10 + HF; 5 / 5A, ASTM A351 Gr. CF8M or ASTM A182 Gr. F316



## CONCENTRIC BUTTERFLY VALVE

### BENEFITS / PROPERTIES

Lug type body butterfly valve, mounting between flanges; concentric stem design; face-to-face dimensions as per API 609; design, testing and construction according to API 609 or EN 593 & ASME B16.34 in current versions.

### SPECIFICATIONS

- » Connections: mounting between flanges ASME B16.5, R.F. – ASME B16.34 standard class for Ø 24" and smaller
- » Mounting between flanges ASME B16.47 Series B, R.F. – ASME B16.34 standard class for Ø 26" and larger
- » Size: 2" – 48"
- » Rating: 150 lbs
- » Material: carbon-steel
- » Trim: 10



## TRIPPLE OFFSET BUTTERFLY VALVE

**KMD**

### BENEFITS / PROPERTIES

Lug-style butterfly valve, mounting between flanges, triple offset design; face-to-face dimensions as per API 609; design, testing and construction according to API 609 or EN 593 & ASME B16.34 in current versions.

### SPECIFICATIONS

- » Connections: mounting between flanges ASME B16.5, R.F. – ASME B16.34 standard class
- » Size: 3" – 24"
- » Rating: 150 lbs
- » Material: carbon-steel
- » Trim: 10



## SIGHT GLASS PISTON VALVE

### BENEFITS / PROPERTIES

Sight flow indicators are added to the process line to check for flow in the pipeline. For gaseous materials the flow is normally shown by a spinner behind the sight glass.

### SPECIFICATIONS

- » Connections: flange ASME B16.5, R.F. – ASME B16.34 standard class
- » Size: 1" – 4"
- » Rating: 150 – 300 lbs
- » Material: carbon-steel, stainless steel



## PISTON VALVE

**KVN**

### BENEFITS / PROPERTIES

KVN series piston valve with handwheel for flow media such as steam, water and standard gases. Piston valves can be used as control or shutoff valves. The piston valve has a unique graphite seat system which allows its use in contaminated media substituting globe valves, for example. Valve connection with welding ends, threads and flanges.

### SPECIFICATIONS

- » Connections: flange ASME B16.5, R.F. – ASME B16.34 standard class
- » ASME B16.11 SW – ASME B16.34 standard class;
- » ASME B1.20.1 threaded female
- » Size: 1/2" – 8"
- » Rating: 150 – 300 lbs
- » Material: carbon-steel, stainless steel
- » Trim: graphite/stainless steel



# GASKETS

## SPIRAL WOUND GASKET (MAXIFLEX)

### BENEFITS / PROPERTIES

- » Highly suitable for and common in refinery applications
- » Handles 500 °C in continuous operation
- » Suitable for applications with pressures up to 420 bar
- » Handles large pressure fluctuations
- » Multiple filling materials and metals to choose from
- » Standard material is graphite

### SPECIFICATIONS

Spiral wound gasket with filling materials graphite (500 °C), PTFE (260 °C), mica (1,000 °C) or mica & graphite (900 °C). The standard design features the inner ring and winding in 316L stainless steel/graphite and the outer ring in carbon-steel.

**Dimensions:** Can be supplied as ring gaskets in DIN, ANSI, and user-defined dimensions.

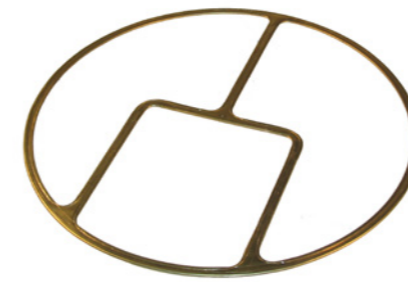

### METAL JACKETED GASKETS

#### BENEFITS / PROPERTIES

- » Economical
- » Easy to handle and install
- » Suitable for high temperatures
- » Suitable for narrow flanges
- » Good blow-out resistance
- » Types: double jacketed, double jacketed corrugated, single jacketed fully enclosed
- » KLINGER Maxigraph

#### SPECIFICATIONS

Metal-jacketed gaskets can be manufactured to suit a range of chemical environments through the selection of a suitable jacketing metal. The following materials are available:

- » Soft iron
- » Stainless steel
- » Monel
- » Inconel
- » others

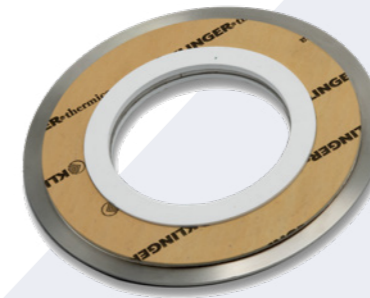

### SAFEGUARD METALLIC GASKET

#### BENEFITS / PROPERTIES

- » Continuous operation up to 260 °C
- » Suitable for RTJ, RF and mismatched RF to RTJ flanges
- » Suitable for pressure ratings from Class 150 to 2500
- » Compressed fiber facings of mica & synthetic fibers bound with NBR on a high-strength metallic core
- » Excellent chemical resistance
- » 3xA non-stick finish
- » Fire-safe according to DIN EN ISO 10497/API 607
- » Fire-safe according to API 6FB

#### SPECIFICATIONS

Can be manufactured with a range of metallic cores including UNS S31254, UNS 32750 and INCONEL 625. High-strength metallic core faced with highly conformable multi-directional e-PTFE and Thermica API 6FB fire-safe sealing faces

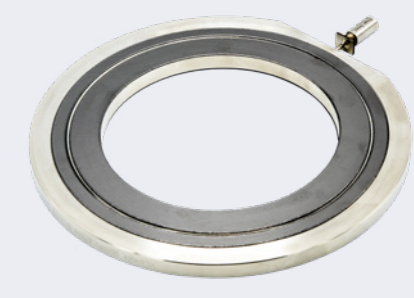

### SENTRY GASKET

#### BENEFITS / PROPERTIES

- » Allows leak testing on individual flanged joints without the need to pressurize the full system
- » Speeds up the leakage testing, reducing plant downtime
- » Significantly reduces the volume of testing media required
- » Validates individual joint integrity at installation reducing the need to reinspect the joint
- » Joints can be tested and adjusted if leakage occurs in one step

#### SPECIFICATIONS

- » Sentry IK: specifically designed for applications where cathodic isolation is required
- » Sentry DS: designed to suit raised-face ASME flanges
- » Sentry SR: specifically designed for hub/clamp connections
- » Sentry RTJ: designed to suit ASME B16.5, API 6A & API 17D flanges
- » Available with octagonal, oval, RX and BX cross-section



### KAMMPROFILE GASKET

#### BENEFITS / PROPERTIES

- » Utilizes a serrated metal core with soft facing material
- » High-pressure gasket with wide seating stress range
- » Excellent tightness even at low bolt loads
- » Suitable for a wide range of operating conditions
- » Provides a high-integrity seal including for thermocycling and shock loading conditions
- » Easy to handle and install
- » Metallic core can be refurbished with a new facing layer and reused

#### SPECIFICATIONS

Kammprofile gasket with facing materials graphite (550 °C), PTFE (260 °C), mica (1,000 °C) and Klingersil C-4430 (250 °C). Kammprofile gaskets can also be manufactured from a range of core materials according to media compatibility and temperature considerations. Can be supplied as ring gaskets in DIN, ANSI, and user-defined dimensions.



### RING TYPE JOINTS

#### BENEFITS / PROPERTIES

- » Can be used for high pressures up to class 2500 and API 20000
- » High-integrity seal at high pressure
- » Available for flat and round bottom groove flanges
- » Temperature range -250 °C to 800 °C

#### SPECIFICATIONS

Manufactured according to ASME B16.20 and API-6A. Wide range of materials available. Ring joint styles: type R-Oval, R-Octagonal, BX, RX. Can be supplied as ring seal gaskets in DIN, ANSI, and user-defined dimensions.

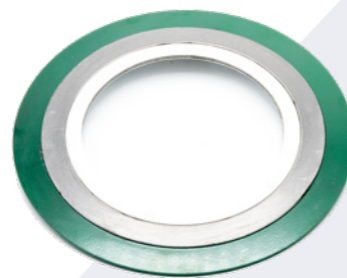

### MAXIFLEX PRO/PRO-X

#### BENEFITS / PROPERTIES

- » Handles 450 °C in continuous operation in combination with high pressure. Designed for use in aggressive chemical applications such as hydrofluoric acid. (PRO)
- » Designed for use in seawater applications. (PRO X)
- » Fire-safe to API-6FB

#### SPECIFICATIONS

**PRO:** outer guide ring: carbon-steel with HF detection paint; sealing element: Monel 400/graphite  
Inner seal: Monel 400/PTFE. Other materials are available according to different operating conditions  
**PRO-X:** outer guide ring: carbon steel with corrosion-resistant coating, sealing element: 316L with mica/graphite/mica, Inner seal: 316L/PTFE, sealing element: 316L with mica/graphite/mica  
**Inner seal:** 316L/PTFE

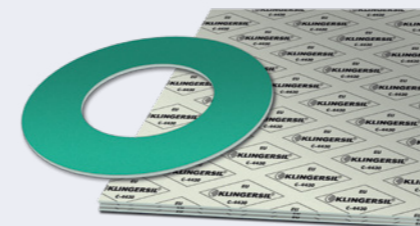

### KLINGERSIL C-4430

#### BENEFITS / PROPERTIES

- » Universal gasket for general use up to 250 °C
- » Very good pressure stability
- » Highly suitable for steam and hot water
- » Does not stick to the flange

#### SPECIFICATIONS

Synthetic and glass fibers bound with NBR, 3xA self-release surfaces. Dimensions, standard sheet. Size: 1,500 x 2,000 mm. Thickness: 0.5 mm, 1.0 mm, 1.5 mm, 2.0 mm, 3.0 mm, 4.0 mm, 5.0 mm. Tolerances: thickness ±10%, length ±50 mm, width ±50 mm. Also available as rings in DIN, ANSI, and user-defined dimensions.

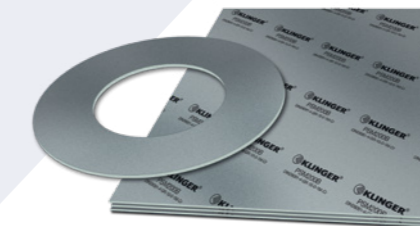

### PSM-AS

#### BENEFITS / PROPERTIES

- » Handles 450 °C in continuous operation in combination with high pressure
- » Suitable for worn flange surfaces
- » Excellent in steam applications
- » Does not stick to the flange
- » Contains no adhesive
- » Perforated stainless steel insert highly resistant to exhaust gases
- » Also available as TA Luft-approved in type TSM

#### SPECIFICATIONS

Graphite with perforated stainless steel insert, AS non-stick surface. Purity: 98%, alt. 99% or 99.85%. Density according to customer specification. Dimensions of standard sheet: 1,000 x 1,000 or 1,500 x 1,500 mm. Thickness: 0.6 mm, 0.8 mm, 1 mm, 1.5 mm, 2 mm, 3 mm. Tolerances: thickness ±5%, length ±5 mm, width ±5 mm. Can be supplied as ring seal gaskets in DIN, ANSI, and user-defined dimensions.



### PSS MILAM

#### BENEFITS / PROPERTIES

- » Milam PSS gaskets are specifically designed for hot, dry gas applications at up to 900 °C and 5 bar
- » Superior high temperature resistance
- » Excellent chemical resistance
- » Recommended for exhaust systems
- » Extremely high oxidation resistance

#### SPECIFICATIONS

Stainless steel 1.4404 insert impregnated with high-quality silicone oil, free of fibers. Dimensions of standard sheet: 1,000 x 1,200 mm. Thickness: 1.3 mm, 2.0 mm, 3.2 mm. Tolerances: thickness ±10%, length ±5 mm, width ±5 mm.

# COMPRESSION PACKINGS

## TOPLINE K3622 LE

### BENEFITS / PROPERTIES

- » Min. operating temperature: -240 °C
- » Max. operating temperature: 650 °C
- » Max. static pressure: 580 bar
- » pH: 0–14
- » A fantastic plant-wide spool packing for block valves
- » High purity of graphite: 99.5–99.9%
- » Passed API 622 3rd Edition FE tests along with Annex-C (high temperature) tests
- » The packing exterior is densely impregnated with lubricating agents to reduce stem friction and a corrosion inhibitor to prevent pitting

### SPECIFICATIONS

Expanded graphite packing with metal wire mesh jacketing around each yarn along with multiple metal wire reinforcements inside each yarn. Standard package: 8 m/roll. Sizes, square profile (mm): 3, 5, 6.5, 8, 9.5, 11, 12.5, 14, 16, 17.5, 19, 20.5, 22, 25. Tolerances: ±0.4 for 3, 5, 6.5. All others ±0.8

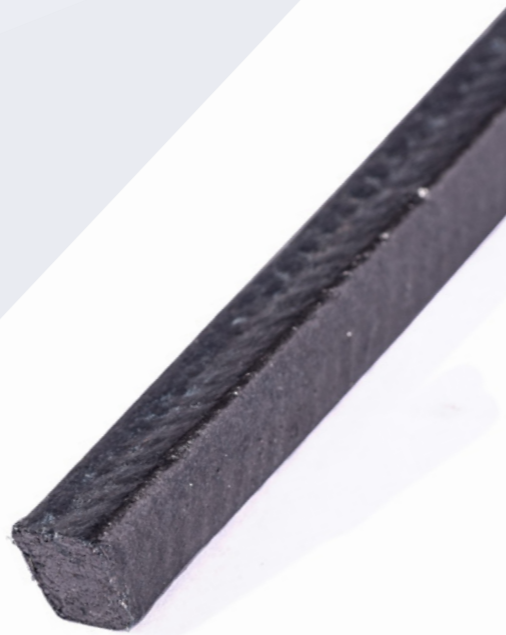

## TOPLINE K25

### BENEFITS / PROPERTIES

- » Min. operating temperature: -100 °C
- » Max. operating temperature: 280 °C
- » Max. static pressure: 250 bar
- » Max. peripheral velocity: 20 m/s
- » pH: 2–12
- » Good chemical resistance
- » Excellent dimensional stability
- » Temperature tolerant

### SPECIFICATIONS

KLINGER K25 is an aramid fiber packing impregnated with a PTFE dispersion. Recommended for use in media containing suspended solid abrasive particles. Standard package: 8 m/box. Sizes, square profile (mm): 3.2, 5, 6.5, 8, 9.5, 11, 12.5, 14, 16, 19, 20, 22, 25. Tolerances: ±0.4 for 3.2, 5.0, 6.5. All others ±0.8.

## TOPLINE K3222

### BENEFITS / PROPERTIES

- » Min. operating temperature: -200 °C
- » Max. operating temperature: 430 °C, suitable for high temperatures, depending on oxygen content
- » Max. steam temperature: 430 °C
- » Max. static pressure: 175 bar
- » Max. peripheral velocity: 20 m/s
- » pH: 0–14
- » Packing for valve and pump servicing
- » Can also be used in low temperatures
- » Permanent resilience
- » Universal packing for valves

### SPECIFICATIONS

Pure exfoliated, expanded graphite packing. Standard package: 8 m/roll. Sizes, square profile (mm): 3.2, 5, 6.5, 8, 9.5, 11, 12.5, 14, 16, 17.5, 19, 20.5, 22, 25. Tolerances: ±0.4 for 3.2, 5.0, 6.5. All others ±0.8.

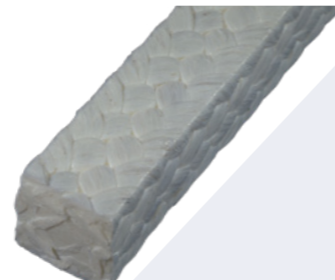

## TOPLINE K55

### BENEFITS / PROPERTIES

- » Min. operating temperature: -200 °C
- » Max. operating temperature: 280 °C
- » Max. static pressure: 250 bar
- » Max. velocity: 20 m/sec
- » pH: 0–14
- » Virtually resistant to all media including strong acids and alkalis
- » Klingerlock braided packing offers excellent sealing & reliability in high-performance applications
- » Good heat transfer properties improve performance in dynamic applications
- » Universal packing material with excellent seal life
- » Clean to handle and requires only minimal gland load to achieve a satisfactory seal

### SPECIFICATIONS

Multiservice packing for both valves & pumping applications. Standard package: 8 m/roll. Sizes, square profile (mm): 6.5, 8, 9.5, 11, 12.5, 14, 16, 17.5, 19, 20.5, 22, 25. Tolerances: ±0.4 for 6.5. All others ±0.8.

## TOPLINE K46

### BENEFITS / PROPERTIES

- » Min. operating temperature: -240 °C
- » Max. operating temperature: 430 °C
- » Max. steam temperature: 650 °C
- » Max. peripheral velocity: 20 m/s
- » Max. static pressure: 200 bar
- » pH: 0–14
- » Virtually resistant to all media over an extensive range of pressures and temperatures
- » The addition of graphite improves the packing's overall capability in dynamic applications
- » An economic alternative to pure graphite packings with reliable sealing performance for valve and pump applications
- » Can be used as header and footer rings with K3222 for high-pressure applications

### SPECIFICATIONS

Carbon-based high-performance multiservice packing for valve and pump applications. Standard package: 8 m/box. Sizes, square profile (mm): 3.2, 5, 6.5, 8, 9.5, 11. Tolerances: ±0.4 for 3.2, 5.0, 6.5. All others ±0.8.

## TOPLINE K54

### BENEFITS / PROPERTIES

- » Max. operating temperature: 260 °C (K54S up to 280 °C)
- » Max. static pressure: 200 bar
- » Max. peripheral velocity: 10 m/s (5 m/s for K54S)
- » pH: 0–14
- » Suitable for aggressive media
- » K54H – designed for pumps
- » K54S – universal packing
- » K54F – pure PTFE packing

### SPECIFICATIONS

Standard package: 8 m/roll. Sizes, square profile (mm): 3.2, 5, 6.5, 8, 9.5, 11, 12.5, 14, 16, 17.5, 19, 20.5, 22, 25. Tolerances: ±0.4 on 3.2, 5.0, 6.5. All others ±0.8.



## REFLEX GAUGES

### BENEFITS / PROPERTIES

Reflex level gauges allow the medium to be viewed through a reflex glass: the side of the glass exposed to the medium is prismatic, while the other side is smooth. The medium level inside the level gauge is indicated based on the light refraction principle.

### SPECIFICATIONS

- » Manufactured of carbon-steel, stainless steel and special materials by request
- » Suitable for steam and process applications
- » Design temperature up to 400 °C
- » Pressure up to 400 bar



### TRANSPARENT LEVEL GAUGE

#### BENEFITS / PROPERTIES

In this kind of level gauge, the medium is contained within two glasses whose surfaces are both smooth. The medium level can be easily observed by looking through the glasses.

#### SPECIFICATIONS

- » Manufactured from carbon-steel, stainless steel and special materials on request
- » Suitable for steam and process applications
- » Design temperature: up to 400 °C
- » Pressure: up to 250 bar
- » A light source can be installed to improve visibility

### MAGNETIC LEVEL GAUGE

#### BENEFITS / PROPERTIES

KLINGER magnetic level gauges are particularly suitable for applications that involve toxic or hazardous liquids or gases and when the following is required: immediate and safe response to level changes, perfect visibility, continuous indication of fluid level, local or remote display.

#### SPECIFICATIONS

- » Manufactured from stainless steel, or special materials by request
- » Suitable for steam and process applications
- » Design temperature: up to 400 °C
- » Pressure: up to 312 bar
- » Suitable for toxic and hazardous fluids
- » Alert functions
- » Very great lengths to customer specifications feasible



### BICOLOR LEVEL GAUGE

#### BENEFITS / PROPERTIES

Bicolor level gauges are a variation of transparent level gauges and mainly used to measure the level of steam at very high pressures. These gauges feature two flat transparent glasses which, together with the gauge body, form the chamber containing the medium.

#### SPECIFICATIONS

- » Manufactured from carbon-steel
- » High-pressure steam applications only
- » Design temperature: up to 356 °C
- » Pressure: up to 225 bar



## EXPANSION JOINTS & HOSES

KLINGER offers metal bellows, lens expansion joints, braided hoses, boiler hoses, high-pressure expansion joints, and expansion joints manufactured from various nickel alloys and stainless steels. In addition, we provide fabric and rubber expansion joints as well as rectangular expansion joints for waste streams, steam pipes as well as chemical and other applications.

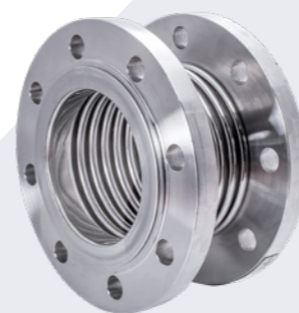

### METAL EXPANSION JOINTS

#### BENEFITS / PROPERTIES

Expansion joints are equipped with carbon-steel or stainless steel pipe connections. Although they can absorb movements in any direction, this type is mainly used for axial movements. This type of expansion joint can be supplied with rings, liners, covers, externally pressurized rods, hinges or gimbals. Available for exhaust gases, liquid medium and steam. The bellows are calculated following the latest EJMA standards.

#### SPECIFICATIONS

- » Connections: flange ASME B16.5, R.F. – ASME B16.34 standard class
- » ASME B16.25 B W – ASME B16.34 standard class
- » Size: 1/2" – 120"
- » Rating: 150 lbs
- » Body materials: carbon-steel, stainless steel, special materials
- » Trim: stainless steel
- » Temperature: -196 °C – +400 °C



### RUBBER EXPANSION JOINTS

#### BENEFITS / PROPERTIES

Rubber provides excellent flexibility in short lengths. Flanges manufactured from various grades of carbon and stainless steel and cast iron in accordance with various industry standards. Up to 110 °C operating temperature and 16 bar operating pressure. Rubber expansion joints are used in a variety of applications, in particular to absorb vibrations.

#### SPECIFICATIONS

- » Connections: flange ASME B16.5, R.F. – ASME B16.34 standard class
- » Size: 1/2" – 120" (please check with us for other sizes)
- » Rating: 150 lbs
- » Bellows material: EPDM, NBR, CR, SBR
- » Flange material: carbon-steel, stainless steel
- » Temperature: up to 110 °C



### METAL HOSES

#### BENEFITS / PROPERTIES

KLINGER flexible metal hoses are manufactured from stainless steel to ensure a long service life. They come in braided and non-braided versions for use in multiple applications and for a wide variety of purposes. The hoses can be supplied with various types of fittings/connections. They provide extremely good flexibility for connecting and transferring various types of process fluids. KLINGER hoses require minimal maintenance.

#### SPECIFICATIONS

- » Size: DN 1/4" – 6"
- » Rating: 150 – 1,500 lbs
- » Bellows material: AISI 304, 316/316L, 321
- » Connection material: carbon-steel, stainless steel, custom
- » Temperature: -196 °C – +400 °C

# PRODUCT OVERVIEW

Product and process mapping for refinery

PROCESS STEP	PROCESS CHARACTERISTICS	VALVES	GASKETS
General media	Air	Resilient-seated ball valves Resilient-seated butterfly valves	Spiral wound gaskets Klingersil C-4430
	Low-pressure steam	Low-pressure bolted bonnet GGC Piston valves	Spiral wound gaskets/ PSM-AS
	High-pressure steam	High-pressure pressure seal GGC	Spiral wound gaskets/ Ring-type joints
	Water	Resilient-seated ball valves Resilient-seated butterfly valves	Spiral wound gaskets Klingersil C-4430
	Hot water	Resilient-seated ball valves Resilient-seated butterfly valves Low-pressure bolted bonnet GGC	Spiral wound gaskets Klingersil C-4430 PSM-AS
Atmospheric/ vacuum distillation	Low-pressure Temperature up to 400 °C	Low-pressure bolted bonnet GGC Dual-plate check valves Triple offset valves Metal seal ball valves Plug valves	Spiral wound gaskets Kammprofile gaskets
Hydrocracking	High-pressure 300-400 °C	Low-pressure bolted bonnet GGC High-pressure pressure seal GGC Dual-plate check valves Triple offset valves Metal seal ball valves Resilient-seated ball valves	Spiral wound gaskets Ring-type joints Kammprofile gaskets
Fluid catalytic cracking	Moderate to high-pressure 500-600 °C	Low-pressure bolted bonnet GGC High-pressure pressure seal GGC Dual-plate check valves Triple offset valves Metal seal ball valves Resilient-seated ball valves	Spiral wound gaskets Ring-type joints Kammprofile gaskets
Hydrotreating	High-pressure 200-400 °C	High-pressure pressure seal GGC Metal seal ball valves	Spiral wound gaskets Ring-type joints Kammprofile gaskets

GLAND PACKINGS	EXPANSION JOINTS	INSTRUMENTATION
TopLine K3222 W/K3222	Metal expansion joints (single/universal designs) Welding ends (KB) Flanged – fixed (SF) Flanged – loose (DF) All types of hardware i.e. tierods, hinges and gimbals can be used	Glass level gauges Bicolor level gauges Magnetic level gauges Glass level gauges Magnetic level gauges Glass level gauges
TopLine K3622 LE		
TopLine K3622 LE		
TopLine K3222 W/K3222 TopLine K46/K55/K54/K10		
TopLine K3222 W/K3222 TopLine K46/K55/K54/K10		
TopLine K55/K46 TopLine K3622 LE	Metal expansion joints (single/universal designs) Welding ends (KB) Flanged – fixed (SF) Flanged – loose (DF) All types of hardware i.e. tierods, hinges and gimbals can be used	Glass level gauges Magnetic level gauges Bicolor level gauges
TopLine K3622 LE TopLine K55/K46	Metal expansion joints (single/universal designs) Welding ends (KB) Flanged – fixed (SF) Flanged – loose (DF) All types of hardware i.e. tierods, hinges and gimbals can be used	Glass level gauges Magnetic level gauges Bicolor level gauges
TopLine K3622 LE TopLine K55/K46	Metal expansion joints (single/universal designs) Welding ends (KB) Flanged – fixed (SF) Flanged – loose (DF) All types of hardware i.e. tierods, hinges and gimbals can be used	Glass level gauges Magnetic level gauges Bicolor level gauges
TopLine K3622 LE TopLine K55/K46	Metal expansion joints (single/universal designs) Welding ends (KB) Flanged – fixed (SF) Flanged – loose (DF) All types of hardware i.e. tierods, hinges and gimbals can be used	Glass level gauges Magnetic level gauges Bicolor level gauges

# PRODUCT OVERVIEW

Product and process mapping for refinery

PROCESS STEP	PROCESS CHARACTERISTICS	VALVES	GASKETS
Visbreaking	Moderate pressure 400-500 °C	Low-pressure bolted bonnet GGC High-pressure pressure seal GGC Dual-plate check valves Triple offset valves Metal seal ball valves	Spiral wound gaskets Ring-type joints Kammprofile gaskets
Delayed coking	High-pressure 500-600 °C	Metal seal ball valves	Spiral wound gaskets Ring-type joints Kammprofile gaskets
Alkylation	Low temperature Low-pressure	Low-pressure bolted bonnet GGC Plug valves Dual-plate check valves Triple offset valves Metal seal ball valves	Spiral wound gaskets Maxiflex Pro/Pro-X Monel + PTFE Kammprofile gaskets

GLAND PACKINGS	EXPANSION JOINTS	INSTRUMENTATION
TopLine K3622 LE TopLine K55/K46	Metal expansion joints (single/universal designs) Welding ends (KB) Flanged – fixed (SF) Flanged – loose (DF) All types of hardware i.e. tierods, hinges and gimbals can be used	Glass level gauges Magnetic level gauges Bicolor level gauges
TopLine K3622 LE TopLine K55/K46	Metal expansion joints (single/universal designs) Welding ends (KB) Flanged – fixed (SF) Flanged – loose (DF) All types of hardware i.e. tierods, hinges and gimbals can be used	Glass level gauges Magnetic level gauges Bicolor level gauges
TopLine K3622 LE TopLine K55/K46	Metal expansion joints (single/universal designs) Welding ends (KB) Flanged – fixed (SF) Flanged – loose (DF) All types of hardware i.e. tierods, hinges and gimbals can be used	Glass level gauges Magnetic level gauges Bicolor level gauges

# PRODUCT OVERVIEW

Product and process mapping for refinery

PROCESS STEP	PROCESS CHARACTERISTICS	VALVES	GASKETS
General media	Air	Resilient-seated ball valves Resilient-seated butterfly valves	Spiral wound gaskets Klingersil C-4430
	Low-pressure steam	Low-pressure bolted bonnet GGC Piston valves	Spiral wound gaskets/ PSM-AS
	High-pressure steam	High-pressure pressure seal GGC	Spiral wound gaskets/ Ring-type joints
	Water	Resilient-seated ball valves Resilient-seated butterfly valves	Spiral wound gaskets Klingersil C-4430
	Hot water	Resilient-seated ball valves Resilient-seated butterfly valves Low-pressure bolted bonnet GGC	Spiral wound gaskets Klingersil C-4430 PSM-AS
Storage	Low-pressure Ambient temperature	Low-pressure bolted bonnet GGC Resilient-seated ball valves Plug valves Triple offset butterfly valves Dual-plate check valves	Spiral wound gaskets Kammprofile gaskets
Hydrotreating	High-pressure 200-400 °C	High-pressure pressure seal GGC Metal seal ball valves	Spiral wound gaskets Ring-type joints Kammprofile gaskets
Hydrogen production	Low to moderate pressure 50-80 °C	Low-pressure bolted bonnet GGC High-pressure pressure seal GGC Dual-plate check valves Triple offset valves Metal seal ball valves Resilient-seated ball valves	PTFE gaskets Metallic/semi-metallic gaskets Rubber-steel gaskets

GLAND PACKINGS	EXPANSION JOINTS	INSTRUMENTATION
TopLine K3222 W/K3222	Metal expansion joints (single/universal designs) Welding ends (KB) Flanged – fixed (SF) Flanged – loose (DF) All types of hardware i.e. tierods, hinges and gimbals can be used	Glass level gauges Bicolor level gauges Magnetic level gauges Glass level gauges Magnetic level gauges Glass level gauges
TopLine K3622 LE		
TopLine K3622 LE		
TopLine K3222 W/K3222 TopLine K46/K55/K54/K10		
TopLine K3222 W/K3222 TopLine K46/K55/K54/K10		
TopLine K3622 LE TopLine K55/K46	Metal expansion joints (single/universal designs) Welding ends (KB) Flanged – fixed (SF) Flanged – loose (DF) All types of hardware i.e. tierods, hinges and gimbals can be used	Glass level gauges Magnetic level gauges Bicolor level gauges
TopLine K3622 LE TopLine K55/K46	Metal expansion joints (single/universal designs) Welding ends (KB) Flanged – fixed (SF) Flanged – loose (DF) All types of hardware i.e. tierods, hinges and gimbals can be used	Glass level gauges Magnetic level gauges Bicolor level gauges
TopLine K3622 LE	Metal expansion joints (single/universal designs) Welding ends (KB) Flanged – fixed (SF) Flanged – loose (DF) All types of hardware i.e. tierods, hinges and gimbals can be used	Glass level gauges Magnetic level gauges Bicolor level gauges



---

**KLINGER The Netherlands**

Hoofdkantoor  
Nikkelstraat 2 | 3067 GR Rotterdam  
T +31 (0)10 455 75 55  
info@klinger.nl

**ELSLOO**

KLINGER Service Center Limburg  
Business Park Stein 208A | 6181 MB Elsloo  
T +31 (0)46 7600 600  
 limburg@klinger.nl

**VELSEN-NOORD**

KLINGER The Netherlands  
Rooswijkweg 200 | 1951 MD Velsen-Noord  
T +31 (0)88 528 2000  
info@klinger.nl