



Liquid Drainers



Liquid Drainers











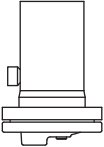

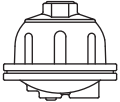

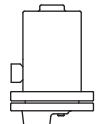

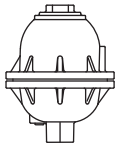
Liquid Drainers ID Charts

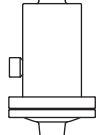

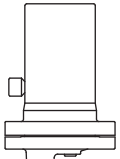
Table LD-441-1. Armstrong Liquid Drainers																
Illustration	Type	Flow Direction	Connection Type	Max. Allow. Press. barg	TMA °C	Body Material	Model	Max. Oper. Press. barg	Connection Size						Located on Page	
									1/2"	3/4"	1"	1 1/4"	1 1/2"	2"		
	Series 1-LDC See-Thru Free Floating Lever Drain Traps Capacities to 690 kg/h	↓	Screwed	10	65	Nylon Cap Polysulfone Body	1-LDC	10	●	★★					LD-444	
	Series 200 BVSU Inverted Bucket Drain Traps Capacities to 3 200 kg/h	↑	Screwed Flanged †	17	232	ASTM A48 Class 30 Cast Iron	211 212 213	17	●	●	●				LD-448	
	Series 800 BVSU Inverted Bucket Drain Traps Capacities to 3 200 kg/h	→	Screwed Flanged †	17	232	ASTM A48 Class 30 Cast Iron	800 811 812 813	10 17 17 17	●	●	●				LD-448	
	Series 880 BVSU Inverted Bucket Drain Traps Capacities to 3 200 kg/h	→	Screwed Flanged †	17	232	ASTM A48 Class 30 Cast Iron	880 881 882 883	10 17 17 17	●	●	●		●			
	Series 300 BVSU Inverted Bucket Drain Traps Capacities to 3 200 kg/h	↑	Screwed Socketweld Flanged †	41 75	343 343	ASTM A105 Forged Steel	312 313	41	●	●	●				LD-448	
	Series 900 BVSU Inverted Bucket Drain Traps Capacities to 3 200 kg/h	→	Screwed Socketweld Flanged †	41	343	ASTM A216 WCB Cast Steel	981 983	22,5 41	●	●	●					
	Series 1, 2, 3, 6 Free Floating Lever Drain Traps Capacities to 22 300 kg/h	↓	Screwed Flanged †	21 17	93 232	ASTM A48 Class 30 Cast Iron	1-LD 2-LD 3-LD 6-LD	21 17		●	●	●		●	●	LD-451
	Series 10 Free Floating Lever Drain Traps Capacities to 4 300 kg/h	↓	Screwed Socketweld Flanged †	35 or 30 41 or 33 39 or 34	38 or 260 38 or 260 38 or 260	304L Stainless Steel	11-LD†† 22-LD 13-LD	28 37 39	●	★★	●					LD-452
	Series 180 Free Floating Lever Drain Traps Capacities to 500 kg/h	↓	Screwed Socketweld	34 or 30	38 or 260	304L Stainless Steel	180-LD 181-LD	16 24	●							LD-453

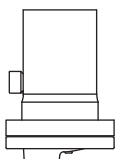
★ 1/4" outlet connection.
 ★★ 1/2" outlet connection.
 † Flange selection may limit pressure and temperature rating.
 †† Side connection not available.

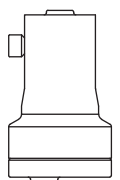
Liquid Drainers

Table LD-442-1. Armstrong Liquid Drainers															
Illustration	Type	Flow Direction	Connection Type	Max. Allow. Press. barg	TMA °C	Body Material	Model	Max. Oper. Press. barg	Connection Size						Located on Page
									1/2"	3/4"	1"	1 1/4"	1 1/2"	2"	
	Series 30 Free Floating Lever Drain Traps Capacities to 19 000 kg/h		Screwed Socketweld Flanged †	41 or 35	38 or 400	ASTM A105 Forged Steel	32-LD	41	●	●				LD-455	
				69 or 41	38 or 400		33-LD	62	●	●	●				
				69 or 41	38 or 400		36-LD	69				●	●		
	Series 21 Fixed Pivot Drain Trap Capacities to 1 230 kg/h		Screwed	17	232	ASTM A48 Class 30 Cast Iron	21	17	●	●					
	Series 21-312 Fixed Pivot Drain Trap Capacities to 1 770 kg/h		Screwed Socketweld Flanged †	41 or 34	38 or 400	ASTM A105 Forged Steel	21-312 21-312V	5,1 41	●	●				LD-456	
	Series 71-A Snap Action Drain Trap Capacities to 885 kg/h		Screwed	17	232	ASTM A48 Class 30 Cast Iron	71-A	17		●	●				
	Series 71-315 Snap Action Drain Trap Capacities to 885 kg/h		Screwed Socketweld Flanged †	69 or 41	38 or 400	ASTM A105 Forged Steel	71-315	69		●	●	●			
	Series 2300 High Leverage Spring-Loaded Float Type Drain Trap Capacities to 6 580 kg/h		Screwed Socketweld Flanged †	69 or 41	38 or 400	ASTM A105 Forged Steel	2313 HLS 2315 HLS 2316 HLS	69	●	●	●		●	●	LD-458
	Series 2400 High Leverage Spring-Loaded Float Type Drain Trap Capacities to 7 380 kg/h		Screwed Socketweld Flanged †	103 or 62	38 or 454	ASTM A182 Gr. F22 Forged Steel	2413 HLS	103	●	●	●				
				125 or 62	38 or 482		2415 HLS	125			●	●	●		
							2416 HLS	110				●	●		
	Series 2500/2600 High Leverage Spring-Loaded Float Type Drain Trap Capacities to 5 000 kg/h		Screwed Socketweld Flanged †	146 or 117	38 or 482	ASTM A182 Gr. F22 Forged Steel	25133G HLS	146	●	●	●				
				174 or 138	38 or 482		25155G HLS	174		●	●	●			
				255 or 207	38 or 482		26155G HLS	255			●	●			

† Flange selection may limit pressure and temperature rating.

Liquid Drainers ID Charts



Table LD-443-1. Armstrong Liquid Drainers																
Illustration	Type	Flow Direction	Connection Type	Max. Allow. Press. barg	TMA °C	Body Material	Model	Max. Oper. Press. barg	Connection Size							Located on Page
									1/2"	3/4"	1"	1 1/2"	2"	2 1/2"	3"	
	Series 2, 3, 6 Free Floating Lever Dual Gravity Drain Traps Capacities to 18 160 kg/h		Screwed Flanged †	17	232	ASTM A48 Class 30 Cast Iron	2-DG	13	●	●						LD-460
							3-DG	17		●	●					
							6-DG	17				●	●			
	Series 30 Free Floating Lever Dual Gravity Drain Traps Capacities to 18 160 kg/h		Screwed Socketweld Flanged †	41 or 35	38 or 400	ASTM A105 Forged Steel	32-DG	22	●	●	●				LD-460	
				69 or 41	38 or 400		33-DG	48		●	●					
				69 or 41	38 or 400		36-DG	69				●	●			
	Series JD & KD Ultra-Capacity Drain Traps Capacities to 137 000 kg/h		Screwed Flanged †	21	343	ASTH A395 Ductile Iron	JD8 KD8 KD10 KD12	20					●	●	●	LD-462
	Series L & M Ultra-Capacity Drain Traps Capacities to 318 000 kg/h		Screwed Flanged †	17	232	ASTM A48 Class 30 Cast Iron	L8 L10 M12	17					●	●	●	
	Series LS & MS Ultra-Capacity Drain Traps Capacities to 318 000 kg/h		Screwed Socketweld Flanged †	31	338	ASTM A216 WCB Cast Steel	LS8 LS10 MS12	31					●	●	●	

† Flange selection may limit pressure and temperature rating.
All models comply with the Pressure Equipment Directive PED 97/23/EC. For details, see specific product page or Armstrong PED Certificate.

Liquid Drainers



1-LDC – A See-Thru Body So You'll Know When It's Working

Benefits You Can See

Reduced maintenance

Stainless steel internals mean corrosion resistance and reduced maintenance.

Positive seating

Free-floating valve mechanism assures positive seating so it prevents air loss. There are no fixed pivots to wear or create friction, and wear points are heavily reinforced for long life.

In-line repairability

In-line connections and an O-ring seal make for quick, easy repairs without dismantling piping. Just unscrew and remove the body for maintenance.

Reduced need for cleaning

Recessed dirt pocket gives dirt a place to accumulate away from the valve seat. Valve seat is 32 mm above the dirt pocket. Compared to other ball float drain traps, the Armstrong 1-LDC reduces dirt fouling and needs less frequent cleaning.

Efficient operation

Simple ball float mechanism discharges only when liquid is present so it doesn't waste air.

An inside look

See-thru body means you can observe changing conditions as they occur. See a problem in the making – instead of having to deal with it after the fact.

Corrosion resistance

Long-lasting polysulfone body and reinforced nylon cap weigh less than 20% of cast iron liquid drain traps. Rugged polysulfone resists corrosion and provides long, trouble-free service life.

Simplified installation

Optional horizontal or vertical inlet with horizontal outlet eliminates the need for extra fittings. Makes installation in existing systems easier. Vertical inlet is 3/4" to accommodate air venting. Requires no electricity.

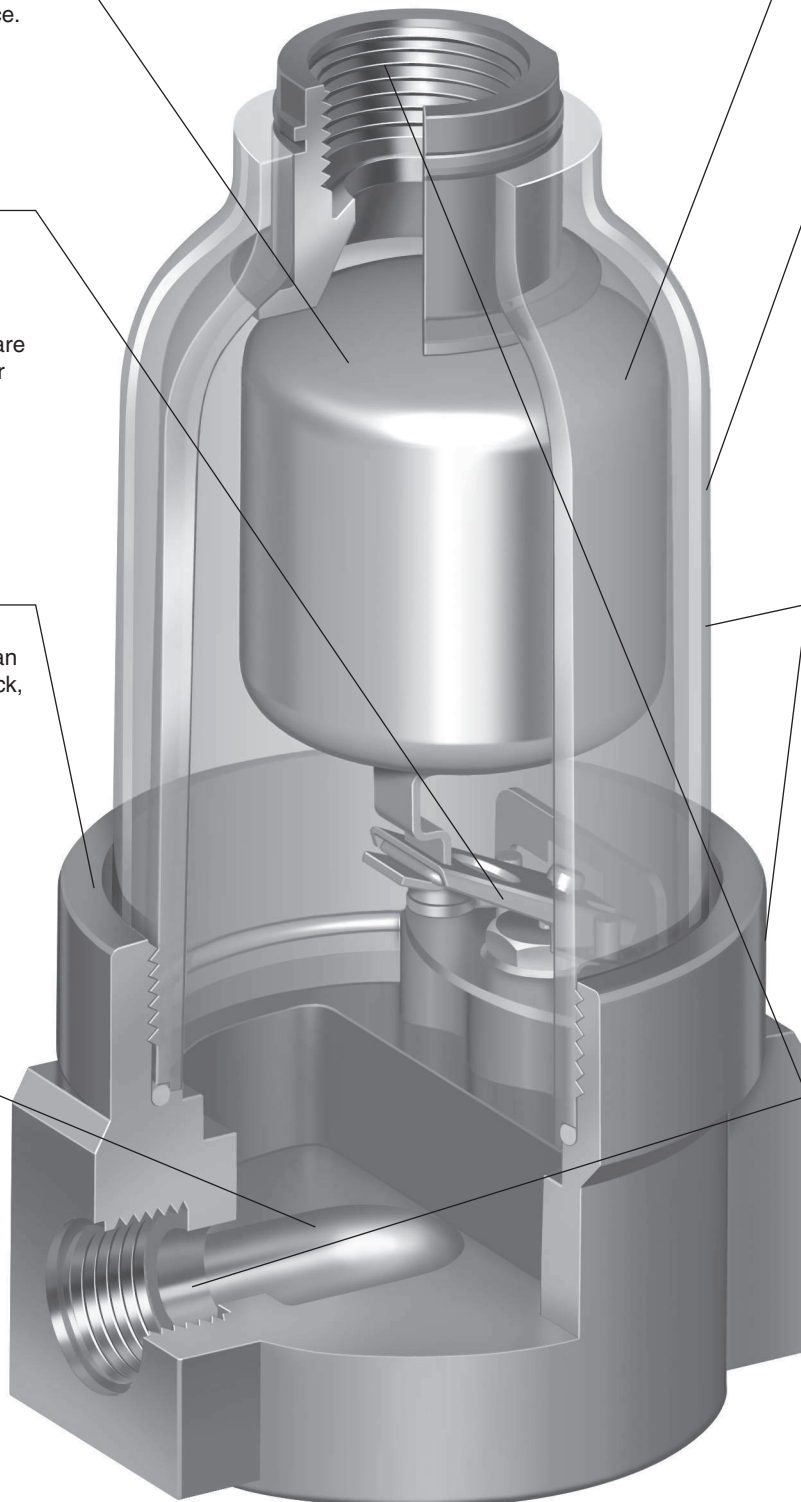

Note: The Armstrong 1-LDC is not recommended for extremely dirty systems or those with heavy oil carryover. The drain trap should not be used in an environment where there are high levels of ketones or chlorinated or aromatic hydrocarbons.

1-LDC – A See-Thru Body So You'll Know When It's Working



Now, you can literally see what you've been missing – the early warning signs of a drain trap or system problem. Since you'll *know* the operating condition of a drain trap, you won't waste time and money scheduling maintenance that isn't needed. In other words, you will be able to react to a condition before it becomes a problem.

A simple ball float mechanism requiring no electricity to operate, the new Armstrong 1-LDC discharges automatically *only* when liquid is present. That means no air loss as with timed devices, which open even when liquid is not present.

Moisture in a compressed air system causes a variety of problems – everything from dirt fouling and potential corrosion to water hammer. Getting the water out – automatically, reliably – builds greater efficiency into your system. In short, pay attention to your compressed air system, and you'll probably pay less to compress air.

Compare...and Save the Difference

Seeing really is believing – especially when you compare the Armstrong see-thru drain trap with cast iron units. Measure the differences in the time and money you can save with a more efficient, easier-to-maintain compressed air system. For more information or technical assistance, contact your local Armstrong Representative.





1-LDC See-Thru Liquid Drainer

For Loads to 690 kg/h...Pressures to 10 bar

Now, you can literally see what you've been missing – the early warning signs of a drain trap or system problem. Since you'll know the operating condition of a drain trap, you won't waste time and money scheduling maintenance that isn't needed. In other words, you'll be able to react to a condition before it becomes a problem.

A simple ball float mechanism needing no electricity to operate, the 1-LDC discharges automatically only when liquid is present. That means no air loss as with timed devices that open even when liquid is not present. Moisture in a compressed air system causes problems. Getting the water out – automatically, reliably – builds greater efficiency into your system.

Table LD-446-1. 1-LDC List of Materials

Name of Part	Material
Cap and Fitting	Reinforced Nylon
Body	Polysulfone*
O-Rings (Cap, Body and Fitting)	Nitrile Elastomer Compound
Float, Lever and Screws	Stainless Steel
Valve & Seat	Stainless Steel
Retainer Ring	Zinc-Plated Steel

* UV sensitive

Table LD-446-2. 1-LDC Maximum Operation Pressures and Capacities

Specific Gravity	1,0		0,95	
	Maximum Operating Pressure	Capacity	Maximum Operating Pressure	Capacity
Orifice Size	bar	kg/h	bar	kg/h
	1/8"	8,3	690	7,6
#38	10,0	510	10,0	490

Capacities given are continuous discharge capacities in kg/h of liquid at pressure differential indicated.

Table LD-446-3. 1-LDC Physical Data

	mm
Inlet Connections	15
Outlet Connection	15
Alternate Inlet or Vent Connection	15
"A"	89
"B"	175
"C"	155
Weight in kg (screwed)	0,45
Maximum Allowable Pressure (Vessel Design)	10 bar @ 65°C
Maximum Operating Pressure	10 bar

All sizes comply with the article 3.3 of the PED (97/23/EC).

Figure LD-446-1.
Typical Drain Trap Location

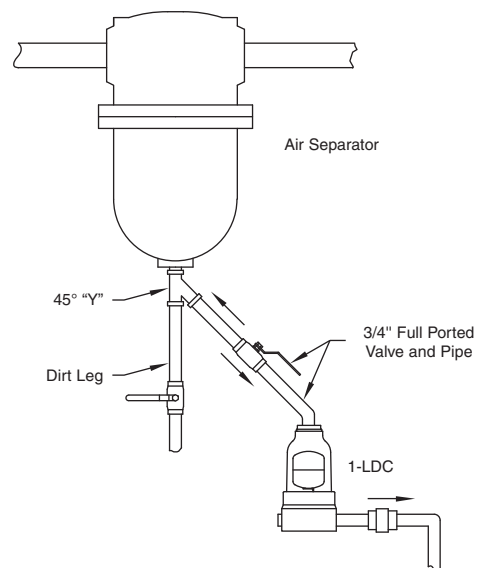

Drain traps dispose of water that collects in many places in a compressed air system. Each drain trap arrangement must be considered individually.

Figure LD-446-2.

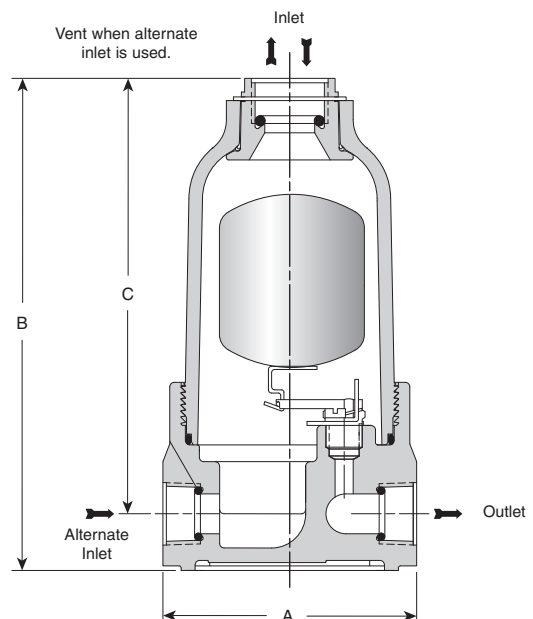

All dimensions and weights are approximate. Use certified print for exact dimensions. Design and materials are subject to change without notice.

Inverted Bucket Drain Traps (BVS Model)

For Loads to 3 200 kg/h...Pressures to 45 bar

Armstrong inverted bucket drain traps are designed for systems where heavy oil and dirt may be encountered. The enlarged bucket vent equipped with a scrub wire (BVS) allows free flow through the bucket vent and discharge through the orifice located in the top of the trap.



BVS Model No.	Body & Cap	Valve & Seat	Bucket & Leverage System	Gasket
800, 811, 812, 813, 880, 881, 882, 883, 211, 212, 213	Cast Iron ASTM A48 Class 30	Stainless Steel	Titanium V&S (pressures higher than 38 bar)	Compressed Asbestos-free
312, 313	Forged Steel ASTM A105			
981, 983	Cast Steel ASTM A216 Grade WCB			

Model No.	800 BVS 880 BVS	811 BVS 881 BVS 211 BVS	812 BVS 882 BVS 212 BVS	312 BVS*	813 BVS 883 BVS 213 BVS 313 BVS* 983 BVS*	981 BVS*
Orifice Size	bar	bar	bar	bar	bar	bar
1/4"	–	–	–	–	8,5	–
7/32"	–	–	–	–	12,5	–
3/16"	–	–	–	–	17,0	3,5
5/32"	–	–	8,5	–	31,0	6,0
1/8"	5,5	8,5	14,0	–	41,0	11,0
7/64"	8,5	14,0	17,0	41,0	–	17,0
#38	10,5	17,0	–	–	–	22,5

Note: Larger capacity models available. Consult your local Armstrong Representative or the Armstrong factory.

* Use steel traps for pressures above 17 bar.

Model No.	800 BVS	811 BVS	812 BVS	813 BVS
Pipe Connections	15 – 20	15 – 20 – 25	15 – 20	20 – 25
Test Plug	1/4"	1/4"	1/2"	3/4"
"A"	95	95	143	178
"B"	138	175	230	298
"C"	127	127	165	197
"CC" "Face-to-Face (flanged PN40*)"	195 – 191	195 – 191 – 197	233 – 229	261
"D"	70	108	137	179
Number of Bolts	6	6	6	6
Weight in kg (screwed)	2,3	2,7	6,8	12,5
Weight in kg (flanged PN40*)	3,6 – 4,3	4,1 – 4,3 – 4,8	8,2 – 9,0	14,3 – 14,8
Maximum Allowable Pressure (Vessel Design)	17 bar @ 232°C			
Maximum Operating Pressure	10,5 bar	17,0 bar		

Note: Larger capacity models available. Consult your local Armstrong Representative or the Armstrong factory.

* Other flange sizes, ratings and face-to-face dimensions are available on request.

All models comply with the article 3.3 of the PED (97/23/EC).

All dimensions and weights are approximate. Use certified print for exact dimensions. Design and materials are subject to change without notice.

Inverted Bucket Drain Traps (BVSW Model)

For Loads to 3 200 kg/h...Pressures to 45 bar



Table LD-449-1. Physical Data - 800 - 980 Series Drain Traps With Integral Strainers in mm (See Pages LD-438 and LD-439 for capacity.)

Model No.	Cast Iron				Cast Steel	
	880 BVSW	881 - 881F BVSW	882 BVSW	883 BVSW	981 BVSW	983 BVSW
Pipe Connections	15 - 20	15 - 20 - 25	15 - 20	20 - 25 - 32	15 - 20	20 - 25
Test Plug	1/4"	1/4"	1/2"	3/4"	1/2"	3/4"
"A"	95	95	143	178	114	184
"B"	154	179	244	314	219	313
"C"	127	127	165	200	137	197
"CC" "Face-to-Face (flanged PN40 - 881F PN16*)	195 - 191	150 - 150 - 160	233 - 229	264 - 264 - 326	196 - 194	282
"D"	87	113	146	187	122	193
Number of Bolts	6	6	6	6	6	6
Weight in kg (screwed & SW)	2,5	2,7	7,0	14,1	5,2	19,5
Weight in kg (flanged PN40 - 881F PN16*)	4,0 - 4,6	3,8 - 4,2 - 4,6	8,8 - 9,4	15,6 - 16,1 - 17,7	7,0	26,0
Maximum Allowable Pressure (Vessel Design)	17 bar @ 232°C				41 bar @ 343°C	41 bar @ 343°C
Maximum Operating Pressure	10,5 bar	17,0 bar			22,5 bar	41,0 bar

Note: Larger capacity models available. Consult your local Armstrong Representative or the Armstrong factory.

* Other flange sizes, ratings and face-to-face dimensions are available on request.

Shade indicates products that are CE Marked according to the PED (97/23/EC). All the other models comply with the Article 3.3 of the same directive.

Table LD-449-2. Physical Data - 200 - 300 Series Drain Traps in mm (See Pages LD-438 and LD-439 for capacity.)

Model No.	Cast Iron			Forged Steel	
	211 BVSW	212 BVSW	213 BVSW	312 BVSW	313 BVSW
Pipe Connections	15	15 - 20	15 - 20 - 25	15 - 20 - 25	15 - 20 - 25
Test Plug	1/8"	3/8"	1/2"	-	-
"A"	108	133	162	171	203
"B"	162	203	273	259	295
"BB" Face-to-Face (flanged PN40 - PN100*)	282	320 - 330	390 - 400 - 392	307 - 314 - 320	343 - 349 - 355
"G"	-	-	-	121	130
"K" (C Outlet to C Inlet)	-	-	-	31,7	36,5
Number of Bolts	6	8	6	6	8
Weight in kg (screwed & SW)	2,7	5,2	9,2	13,6	22,0
Weight in kg (flanged PN40 - PN100*)	4,1	7,0 - 7,6	11 - 11,6 - 12	14,5 - 15,5 - 16	22,5 - 23,5 - 24
Maximum Allowable Pressure (Vessel Design)	17 bar @ 232°C			41 bar @ 343°C	75 bar @ 343°C
Maximum Operating Pressure	17,0 bar			41,0 bar	45,0 bar

Note: Larger capacity models available. Consult your local Armstrong Representative or the Armstrong factory.

* Other flange sizes, ratings and face-to-face dimensions are available on request.

Shade indicates products that are CE Marked according to the PED (97/23/EC). All the other models comply with the Article 3.3 of the same directive.

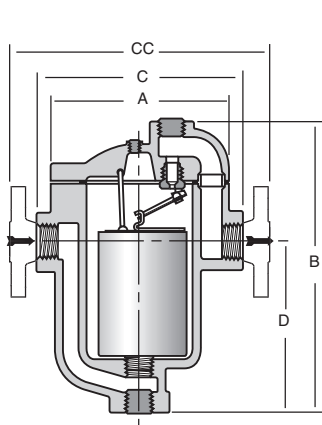

Figure LD-449-1.
Series 800

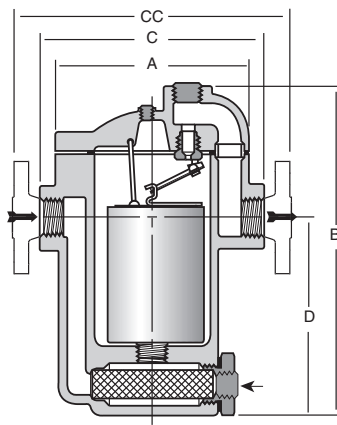

Figure LD-449-2.
Series 880 & 980

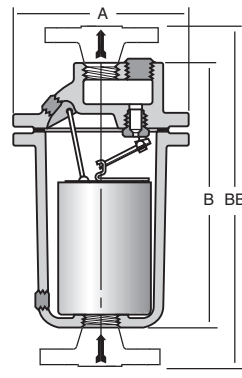

Figure LD-449-3.
Series 200

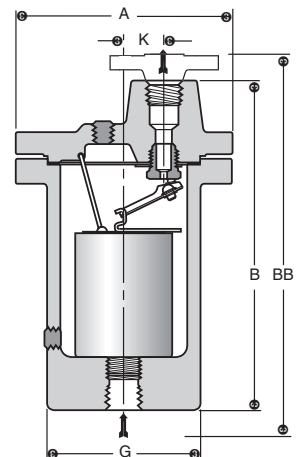

Figure LD-449-4.
Series 300

Liquid Drainers

All dimensions and weights are approximate. Use certified print for exact dimensions. Design and materials are subject to change without notice.



Free Floating Lever Drain Traps

For Loads to 22 700 kg/h...Pressures to 69 bar

Table LD-450-1. Max. Oper. Press. in bar for Handling Different Specific Gravity Liquids With Orifices Available in Guided Free Floating Lever Drain Traps (See pg. LD-438 and LD-439)

Model No.	Sp. Grav.	Maximum Operating Pressure in bar											
		1,00	0,95	0,90	0,85	0,80	0,75	0,70	0,65	0,60	0,55	0,50	
		Orifice (in)											
1-LD	1/8"	8,3	7,6	6,8	6,0	5,2	4,4	3,6	2,8	2,0	1,2	0,4	
	7/64"	9,9	9,0	8,0	7,1	6,1	5,2	4,3	3,3	2,4	1,4	0,5	
	#38	12,5	11,0	10,2	9,0	7,8	6,6	5,4	4,2	3,0	1,8	0,6	
	5/64"	20,7	19,9	17,8	15,7	13,7	11,6	9,5	7,4	5,3	3,2	1,1	
11-LD	1/8"	12,1	11,1	10,1	9,0	7,9	6,9	5,8	4,8	3,7	2,7	1,6	
	7/64"	14,0	13,0	12,0	10,7	9,4	8,2	6,9	5,7	4,4	3,2	1,9	
	#38	18,0	17,0	15,0	14,0	12,0	10,4	8,8	7,2	5,6	4,0	2,5	
	5/64"	28,0	28,0	27,0	24,0	21,0	18,0	15,0	13,0	9,9	7,1	4,3	
2-LD to 17 bar 22-LD to 37 bar	5/16"	1,5	1,4	1,3	1,1	1,0	0,9	0,8	0,7	0,5	0,4	0,3	
	1/4"	2,5	2,3	2,1	1,9	1,7	1,5	1,3	1,1	0,9	0,7	0,5	
	3/16"	5,5	5,0	4,6	4,2	3,7	3,3	2,8	2,4	2,0	1,5	1,1	
	5/32"	9,4	8,7	7,9	7,2	6,4	5,6	4,9	4,1	3,4	2,6	1,8	
	1/8"	16,1	14,8	13,5	12,2	10,9	9,6	8,4	7,1	5,8	4,5	3,2	
	7/64"	20,6	19,0	17,3	15,7	14,0	12,0	10,7	9,0	7,4	5,7	4,0	
	#38	25,7	23,6	21,6	19,5	17,4	15,0	13,0	11,2	9,2	7,1	5,0	
	5/64"	37,0	33,0	32,0	29,0	26,0	23,0	20,0	17,0	14,0	10,5	7,4	
32-LD	5/16"	2,0	1,8	1,6	1,4	1,2	1,0	0,9	0,7	0,5	0,3	0,1	
	1/4"	3,3	3,0	2,6	2,3	2,0	1,7	1,4	1,1	0,8	0,5	0,2	
	3/16"	7,2	6,5	5,8	5,2	4,5	3,8	3,1	2,4	1,8	1,1	0,4	
	5/32"	12,0	11,0	10,0	8,9	7,7	6,5	5,4	4,2	3,0	1,9	0,7	
	1/8"	21,0	19,0	17,0	15,0	13,0	11,0	9,0	7,2	5,2	3,2	1,2	
	7/64"	27,0	25,0	22,0	19,0	17,0	14,0	12,0	9,0	6,6	4,1	1,5	
	#38	34,0	31,0	27,0	24,0	21,0	18,0	15,0	11,0	8,0	5,1	1,9	
	5/64"	41,0	41,0	40,0	36,0	31,0	26,0	22,0	17,0	12,0	7,0	2,8	
3-LD to 17 bar (Cast Iron) 13-LD to 39 bar (Stainless) 33-LD to 62 bar (Steel)	1/2"	1,1	1,0	0,9	0,8	0,7	0,6	0,5	0,4	0,3	0,2	0,1	
	3/8"	2,3	2,1	1,9	1,7	1,5	1,3	1,1	0,9	0,7	0,5	0,3	
	5/16"	3,7	3,4	3,0	2,7	2,4	2,1	1,7	1,4	1,1	0,8	0,4	
	9/32"	4,9	4,5	4,0	3,6	3,2	2,7	2,3	1,9	1,4	1,0	0,6	
	1/4"	7,4	6,7	6,1	5,4	4,8	4,1	3,5	2,8	2,2	1,5	0,9	
	7/32"	10,5	9,6	8,7	7,7	6,8	5,9	5,0	4,0	3,1	2,2	1,2	
	3/16"	16,0	14,0	13,0	12,0	10,3	8,9	7,5	6,1	4,7	3,3	1,9	
	5/32"	25,0	23,0	20,0	18,0	16,0	14,0	12,0	9,5	7,3	5,1	2,9	
	1/8"	50,0	46,0	41,0	37,0	32,0	28,0	24,0	19,0	15,0	10,3	5,9	
	7/64"	62,0	58,0	53,0	47,0	41,0	36,0	30,0	25,0	19,0	13,0	7,6	
	6-LD Cast Iron	1 1/16"	1,4	1,3	1,2	1,1	1,0	0,9	0,8	0,7	0,6	0,5	0,4
		7/8"	2,2	2,1	1,9	1,8	1,6	1,4	1,3	1,1	1,0	0,8	0,6
3/4"		3,2	3,0	2,8	2,5	2,3	2,1	1,9	1,6	1,4	1,2	0,9	
5/8"		4,9	4,6	4,2	3,9	3,5	3,2	2,8	2,5	2,1	1,8	1,4	
9/16"		6,5	6,1	5,6	5,2	4,7	4,2	3,8	3,3	2,8	2,4	1,9	
1/2"		9,5	8,8	8,1	7,5	6,8	6,1	5,4	4,8	4,1	3,4	2,8	
7/16"		13,0	13,0	12,0	11,0	10,0	8,7	7,7	6,8	5,8	4,9	3,9	
3/8"		17,0	17,0	17,0	17,0	15,0	14,0	12,0	11,0	9,0	7,7	6,2	
11/32"		17,0	17,0	17,0	17,0	17,0	17,0	16,0	14,0	12,0	10,0	8,2	
5/16"		17,0	17,0	17,0	17,0	17,0	17,0	17,0	17,0	16,0	13,0	11,0	
9/32"		17,0	17,0	17,0	17,0	17,0	17,0	17,0	17,0	17,0	17,0	14,0	
1/4"		17,0	17,0	17,0	17,0	17,0	17,0	17,0	17,0	17,0	17,0	17,0	
7/32"		17,0	17,0	17,0	17,0	17,0	17,0	17,0	17,0	17,0	17,0	17,0	
3/16"	17,0	17,0	17,0	17,0	17,0	17,0	17,0	17,0	17,0	17,0	17,0		
36-LD Forged Steel	1 1/16"	1,1	1,0	0,9	0,8	0,7	0,6	0,5	0,4	0,3	0,2	0,1	
	7/8"	1,7	1,6	1,4	1,3	1,1	0,95	0,79	0,63	0,47	0,31	0,16	
	3/4"	2,5	2,3	2,1	1,8	1,6	1,4	1,1	0,91	0,68	0,45	0,22	
	5/8"	3,9	3,5	3,1	2,8	2,4	2,1	1,7	1,4	1,05	0,69	0,34	
	9/16"	5,1	4,6	4,2	3,7	3,2	2,8	2,3	1,8	1,4	0,92	0,46	
	1/2"	7,4	6,7	6,0	5,4	4,7	4,0	3,4	2,7	2,0	1,3	0,66	
	7/16"	10,5	9,6	8,6	7,6	6,7	5,7	4,8	3,8	2,9	1,9	0,94	
	3/8"	17,0	15,0	14,0	12,0	10,5	9,0	7,5	6,0	4,5	3,0	1,5	
	11/32"	22,0	20,0	18,0	16,0	14,0	12,0	10,0	8,0	6,0	4,0	2,0	
	5/16"	28,0	26,0	23,0	21,0	18,0	15,0	13,0	10,3	7,7	5,1	2,5	
	9/32"	37,0	34,0	30,0	27,0	24,0	20,0	17,0	13,0	10,1	6,7	3,3	
	1/4"	54,0	49,0	44,0	39,0	35,0	30,0	25,0	20,0	15,0	9,8	4,9	
	7/32"	69,0	69,0	63,0	56,0	49,0	42,0	35,0	28,0	21,0	14,0	6,9	
3/16"	69,0	69,0	69,0	69,0	69,0	69,0	68,0	57,0	46,0	34,0	23,0		
Specific Gravity		1,00	0,95	0,90	0,85	0,80	0,75	0,70	0,65	0,60	0,55	0,50	

Note: If specific gravity falls between those shown in the chart, use the next lower gravity. For example, if specific gravity is 0,73, use 0,70 gravity data.

High Temperature Service

Maximum allowable working pressures of floats decrease at temperatures above 37,8°C. Allow for approximately:

- 10% decrease at 93,3°C
- 15% decrease at 148,9°C
- 20% decrease at 204,4°C

The float is not always the limiting factor, however. Consult with Armstrong Application Engineering if you have a high-temperature application that also requires maximum operating pressures.

Free Floating Guided Lever Drain Traps

For Loads to 22 300 kg/h...Pressures to 21 bar



Armstrong's cast iron, free-floating guided lever drain traps use the same bodies, caps, lever mechanisms, valves and seats of Armstrong inverted bucket steam traps that have been proven in years of service. Elliptical floats and high leverage make it possible to open large orifices to provide adequate capacity for drain trap size and weight.

The hemispherical valve, seat and leverage of the 1-LD, 2-LD, 3-LD and 6-LD cast iron traps are identical in design, materials and workmanship to those for saturated steam service up to 21 bar with the exception of the addition of a guidepost to assure a positive, leaktight valve closing under all conditions.

Model No.	Valve & Seat	Leverage System	Float	Body & Cap	Gasket
1-LD 2-LD 3-LD 6-LD		Stainless Steel		Cast Iron ASTM A48 Class 30	Compressed Asbestos-free

For information on special materials, consult the Armstrong Application Engineering Department.

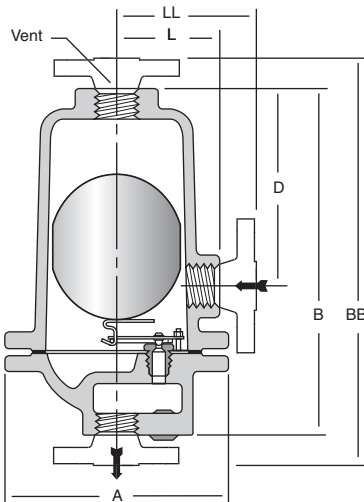

Figure LD-451-1.

Models 2-LD, 3-LD and 6-LD cast iron guided lever drain traps. Model 1-LD has standard top inlet and optional side connection.



Model No.	Cast Iron			
	1-LD	2-LD	3-LD	6-LD
Pipe Connections	15*	15 – 20	15 – 20 – 25	40 – 50
"A"	95	133	162	259
"B"	140	203	273	432
"BB" (PN40**)	N/A	320 – 330	400 – 392	562 – 568
"D"	73	111	155	213
"K" (☉ Outlet to ☉ Inlet)	21	–	–	–
"L"	48	62	73	123
"LL" (PN40**)	N/A	179 – 189	142 – 134	180 – 186
Weight in kg (screwed)	1,8	6	10	36
Weight in kg (flanged PN40**)	N/A	8,7 – 9,6	13,6 – 14,2	42,6 – 45,0
Maximum Allowable Pressure (Vessel Design)	21 bar @ 93°C	17 bar @ 232°C		17 bar @ 232°C

Note: Vessel design pressure may exceed float collapse pressure in some cases.

Pipe size of vent connection is same as that of inlet and outlet connections.

* 1/4" outlet.

** Other flange sizes, ratings and face-to-face dimensions are available on request.

† For pressures not exceeding 17 bar, a maximum temperature of 232°C is allowed.

Shade indicates products that are CE Marked according to the PED (97/23/EC). All the other models comply with the Article 3.3 of the same directive.

All dimensions and weights are approximate. Use certified print for exact dimensions. Design and materials are subject to change without notice.

Armstrong's stainless steel, free-floating guided lever drain traps use the same bodies, caps, lever mechanisms, valves and seats of Armstrong inverted bucket steam traps that have been proven in years of service. Elliptical floats and high leverage make it possible to open large orifices to provide adequate capacity for drain trap size and weight.

The hemispherical valve, seat and leverage of the 11-LD, 22-LD and 13-LD stainless steel traps are identical in design, materials and workmanship to those for saturated steam service up to 39 bar with the exception of the addition of a guidepost to assure a positive, leaktight valve closing under all conditions.

Model No.	Valve & Seat	Leverage System	Float	Body & Cap	Gasket
11-LD 22-LD 13-LD	Stainless Steel			Sealed Stainless Steel, 304L	-

For information on special materials, consult the Armstrong Application Engineering Department.

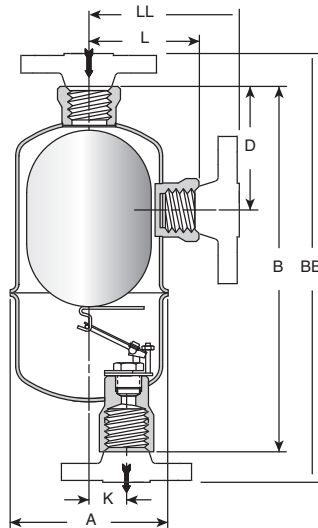

Figure LD-452-1.

Models 11-LD, 22-LD and 13-LD stainless steel guided lever liquid drain trap with sealed, tamperproof construction.



Model No.	Stainless Steel		
	11-LD**	22-LD	13-LD
Pipe Connections	20*	20	25
"A"	70	100	114
"B"	183	221	289
"BB" (PN40***)	225 – 230	271	375
"D"	-	76	156
"K"	14	22	30
"L"	-	67	83
"LL" (PN40***)	-	117	126
Weight in kg (screwed & SW)	0,8	2,3	3,4
Weight in kg (flanged PN40***)	2,9 – 4,0	5,2	7,3
Maximum Allowable Pressure (Vessel Design)	35 bar @ 38°C 30 bar @ 260°C	41 bar @ 38°C 33 bar @ 260°C	39 bar @ 38°C 34 bar @ 260°C

Note: Vessel design pressure may exceed float collapse pressure in some cases.

Pipe size of vent connection is same as that of inlet and outlet connections.

* 1/2" outlet.

** No side connection

*** Standard flanges are in carbon steel, stainless steel flanges are optional. Other flange sizes, ratings and face-to-face dimensions are available on request. Shade indicates products that are CE Marked according to the PED (97/23/EC). All the other models comply with the Article 3.3 of the same directive.

All dimensions and weights are approximate. Use certified print for exact dimensions. Design and materials are subject to change without notice.

180 Series Free Floating Lever Drain Traps

All Stainless Steel for Horizontal Installation
For pressures to 28 bar . . . Capacities to 900 kg/h



Armstrong's stainless steel, free-floating guided lever drain traps use the same bodies, caps, lever mechanisms, valves and seats as Armstrong inverted bucket steam traps that have been proven in years of service. Elliptical floats and high leverage make it possible to open large orifices to provide adequate capacity for drain trap size and weight.

The hemispherical valve, seat and leverage of the 180-LD and 181-LD stainless steel traps are identical in design, materials and workmanship to those for saturated steam service up to 39 bar, except that the 180 Series traps have a guidepost to ensure a positive, leak-tight valve closing under all conditions. The 180 Series is designed for situations where mounting a drainer close to the floor is critical. A back vent connection is required.



Table LD-453-1. 180 Series List of Materials				
Model No.	Valve & Seat	Leverage System	Float	Body & Cap
180-LD	Stainless Steel			Sealed Stainless Steel 304L
181-LD				

Table LD-453-2. Physical Data (dimensions in mm) Armstrong 180 Series Free Floating Lever Drain Traps		
Pipe Connections	15	20
"A" Diameter	68	68
"B" Height	135	167
"C" Face to Face	110	110
"D" Bottom to \varnothing Inlet	113	141
Weight in kg	0,8	1,1

All models comply with the article 3.3 of the PED (97/23/EC).

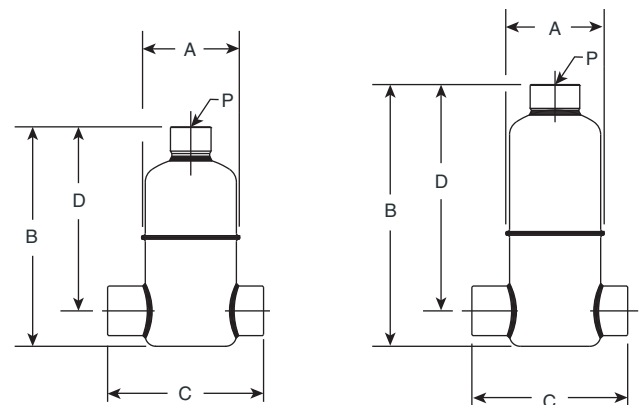
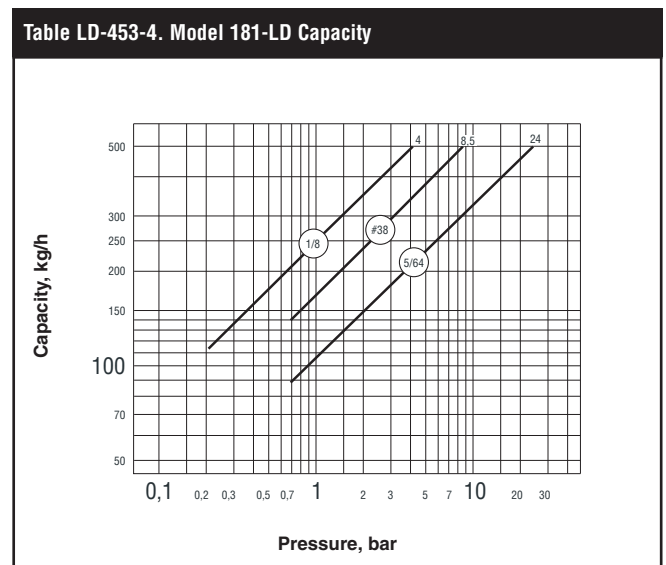
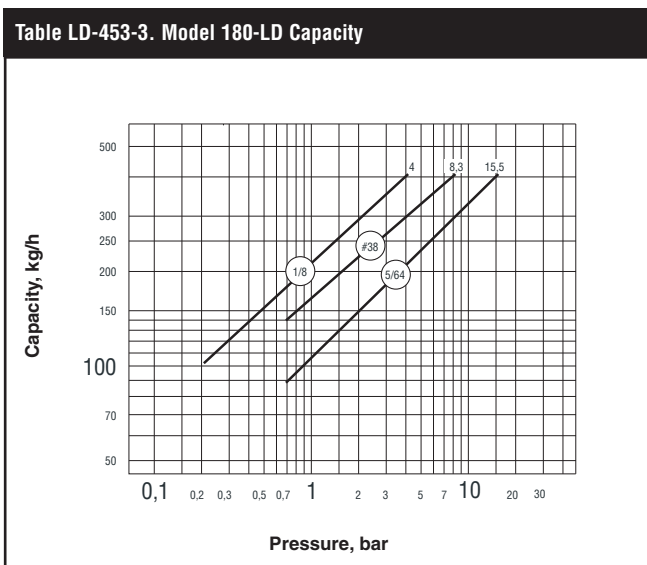

Figure LD-35.
Model 180-LD

Figure LD-36.
Model 181-LD



All dimensions and weights are approximate. Use certified print for exact dimensions. Design and materials are subject to change without notice.

Free Floating Guided Lever Drain Traps

For Loads to 19 000 kg/h...Pressures to 69 bar



Armstrong's forged steel, free-floating guided lever drain traps use the same bodies, caps, lever mechanisms, valves and seats of Armstrong inverted bucket steam traps that have been proven in years of service. Elliptical floats and high leverage make it possible to open large orifices to provide adequate capacity for drain trap size and weight.

The hemispherical valve, seat and leverage of the 32-LD, 33-LD and 36-LD stainless steel traps are identical in design, materials and workmanship to those for saturated steam service up to 69 bar with the exception of the addition of a guidepost to assure a positive, leaktight valve closing under all conditions.

Model No.	Valve & Seat	Leverage System	Float	Body & Cap	Gasket
32-LD 33-LD 36-LD	Stainless Steel			Forged Steel ASTM A105	Compressed Asbestos-free

For information on special materials, consult the Armstrong Application Engineering Department.

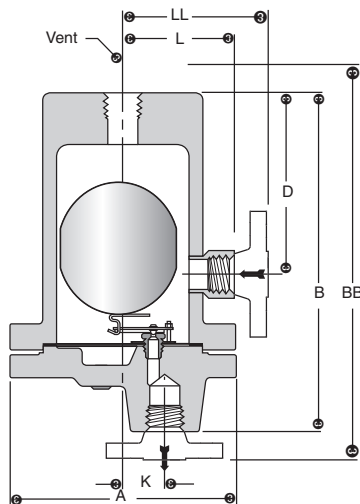

Figure LD-455-1.

Models 32-LD, 33-LD and 36-LD forged steel guided lever drain trap. Socketweld or flanged connections are also available.



Model No.	Forged Steel		
	32-LD †	33-LD †	36-LD †
Pipe Connections	15 – 20 – 25	15 – 20 – 25	40 – 50
"A"	171	203	302
"B"	259	295	435
"BB" (PN100*)	300 – 305	343 – 349 – 355	500 – 505
"D"	141	154	229
"K"	32	37	54
"L"	86	98	154
"LL" (PN100*)	127 – 132	145 – 153 – 159	198 – 204
Weight in kg (screwed & SW)	14	22	74
Weight in kg (flanged PN100*)	15,8 – 17,8	25,0 – 26,0	83,2 – 87,2
Maximum Allowable Pressure (Vessel Design)	41 bar @ 38°C 35 bar @ 400°C	69 bar @ 38°C 41 bar @ 400°C	

Note: Vessel design pressure may exceed float collapse pressure in some cases.

Pipe size of vent connection is same as that of inlet and outlet connections.

† Available in Type 316 stainless steel. Consult factory.

* Other flange sizes, ratings and face-to-face dimensions are available on request.

Shade indicates products that are CE Marked according to the PED (97/23/EC). All the other models comply with the Article 3.3 of the same directive.

All dimensions and weights are approximate. Use certified print for exact dimensions. Design and materials are subject to change without notice.



Fixed Pivot and Snap Action Drain Traps

For Loads to 1 770 kg/h...Pressures to 69 bar

Continuous Flow or On-Off Float Type Drain Traps

Armstrong's line of fixed lever and snap action drain traps includes two basic models available in cast iron and forged steel. The floats are light enough to handle light liquids.

No. 21 – A small, high-quality, economical drain trap for use on drainage jobs where dirt and oil are not encountered. It employs a single lever with a fixed pivot.

No. 21-312 – Forged steel version of the No. 21 with larger float and higher leverage.

No. 71-A – Wide open, tight-shut drain trap for use where fine dirt and grit may be present or where liquid load is light. A flat spring in the leverage system holds the valve closed until the trap body is nearly full of water. Then it snaps open, washing dirt through. When the trap body is nearly empty, the spring snaps the valve shut.

No. 71-315 – Forged steel version of No. 71-A.

Caution: Ball float drain traps are not recommended where heavy oil, sludge or considerable dirt are encountered in lines. Under these circumstances use Armstrong inverted bucket BVSU traps.

Table LD-456-1. Maximum Operating Pressures in bar for Handling Different Specific Gravity With Orifices Available in Fixed Lever and Snap Action Drain Traps (See pages LD-438 and LD-439)

Model No.	Sp. Grav.	1,00	0,95	0,90	0,85	0,80	0,75	0,70	0,65	0,60	0,55	0,50	
		Maximum Operating Pressure in bar @ 38°C											
	Orifice Size (in)	bar	bar	bar	bar	bar	bar	bar	bar	bar	bar	bar	
21	1/4"	1,5	1,4	1,3	1,1	1,0	0,9	0,8	0,7	0,5	0,4	0,3	
	7/32"	1,9	1,8	1,6	1,5	1,0	1,2	1,0	0,9	0,7	0,6	0,4	
	3/16"	2,6	2,4	2,2	2,0	1,8	1,6	1,4	1,2	1,0	0,7	0,5	
	5/32"	3,8	3,5	3,2	2,9	2,6	2,3	2,0	1,7	1,4	1,1	0,8	
	9/64"	4,6	4,2	3,9	3,5	3,1	2,8	2,4	2,1	1,7	1,3	1,0	
	1/8"	5,8	5,4	4,9	4,4	4,0	3,5	3,0	2,6	2,1	1,7	1,2	
	3/32"	10,2	9,4	8,6	7,7	6,9	6,1	5,3	4,5	3,7	2,9	2,1	
	5/64"	14,0	13,0	12,0	11,0	9,9	8,7	7,6	6,4	5,3	4,1	3,0	
1/16"	17,0	17,0	17,0	17,0	15,0	13,0	12,0	9,9	8,1	6,3	4,6		
21-312*	96 g Float	1/4"	2,9	2,7	2,5	2,3	2,1	1,9	1,7	1,5	1,3	1,1	0,9
		7/32"	3,8	3,5	3,2	3,0	2,7	2,5	2,2	2,0	1,7	1,5	1,2
		3/16"	5,1	4,7	4,4	4,0	3,7	3,4	3,0	2,7	2,3	2,0	1,6
		5/32"	14,0	14,0	13,0	12,0	10,6	9,6	8,6	7,6	6,6	5,6	4,6
	128 g Float	9/64"	16,0	15,0	14,0	14,0	13,0	12,0	10,6	9,4	8,1	6,9	5,7
		1/8"	20,0	18,0	17,0	15,0	14,0	14,0	13,0	12,0	10,2	8,7	7,2
		3/32"	34,0	32,0	29,0	27,0	24,0	21,0	19,0	16,0	14,0	14,0	13,0
	170 g Float	5/64"	41,0	37,0	34,0	34,0	34,0	30,0	27,0	23,0	19,0	15,0	14,0
		1/16"	41,0	41,0	41,0	41,0	39,0	34,0	34,0	34,0	29,0	23,0	17,0
	71-A & 71-315	1/4"	0,7	0,7	0,7	0,7	**	**	**	**	–	–	–
		3/16"	1,4	1,4	1,4	1,4	**	**	**	**	–	–	–
		1/8"	6,9	6,9	6,9	6,9	**	**	**	**	–	–	–
7/64"		14,0	14,0	14,0	14,0	**	**	**	**	–	–	–	
71-A	5/64"	17,0	17,0	17,0	17,0	–	–	–	–	–	–	–	
71-315	5/64"	35,0	35,0	35,0	35,0	–	–	–	–	–	–	–	
	1/16"	69,0	69,0	69,0	69,0	–	–	–	–	–	–	–	

Note: If actual specific gravity falls between those shown in above table, use next lower. For example, if actual gravity is 0,73, use 0,70 gravity data.

* 5/32" orifice (and smaller) utilizes higher leverage mechanism designated 21-312V.

** For applications on liquids of specific gravity 0,65 to 0,85, consult factory.

Fixed Pivot and Snap Action Drain Traps

For Loads to 1 770 kg/h...Pressures to 69 bar



Model No.	Cast Iron		Forged Steel	
	21 †	71-A*	21-312 †	71-315*
Pipe Connections	15 – 20	20 – 25	15 – 20 – 25	20 – 25 – 32 – 40
"A"	157	216	171	248
"B"	133	273	259	381
"BB" (PN100**)	–	–	300 – 305 – 313	433 – 433 – 437
"D"	–	108	141	198
"K"	33	–	32	–
"L"	–	89	86	117
"LL" (PN100**)	–	–	127 – 132 – 140	169 – 169 – 173
Weight in kg (screwed & SW)	4	13	14	42
Weight in kg (flanged PN100**)	–	–	15,8 – 17,8 – 18,8	43,5 – 46,5 – 48,8
Maximum Allowable Pressure (Vessel Design)	17 bar @ 232°C		41 bar @ 38°C 34 bar @ 400°C	69 bar @ 38°C 41 bar @ 400°C

† Cast 316 stainless steel body and cap with all stainless steel internals available. Aluminum body and cap available for Model 21 only. Consult factory.

* Snap action drain traps **should not** be used where load exceeds 54 kg/h. Use on greater loads shortens spring life.

** Other flange sizes, ratings and face-to-face dimensions are available on request.

All models comply with the article 3.3 of the PED (97/23/EC).

Table LD-457-2. 21-LD and 71-LD List of Materials					
Model No.	Valve & Seat	Leverage System	Float	Body & Cap	Gasket
21	Stainless Steel			Cast Iron ASTM A48 Class 30	Compressed Asbestos-free
71-A				Forged Steel* ASTM A105	
21-312 71-315					

* Model 71-315 cap is cast steel.

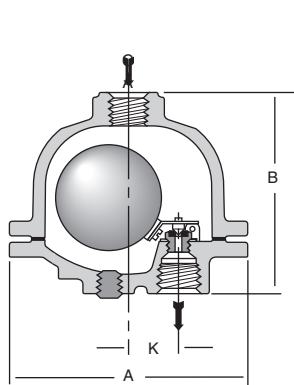
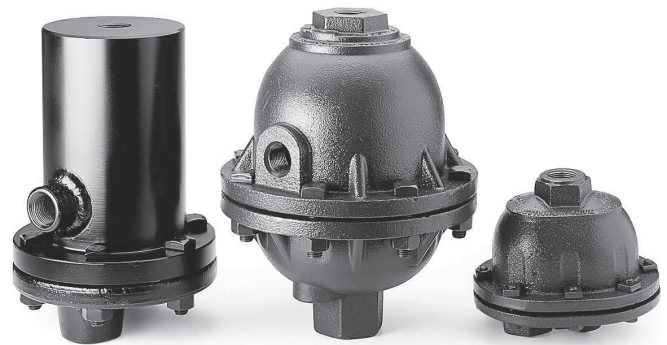

Figure LD-457-1.
Model 21 cast iron fixed lever drain trap.

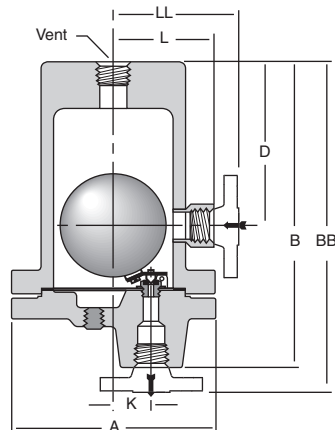

Figure LD-457-2.
Model 21-312 forged steel fixed lever drain trap.

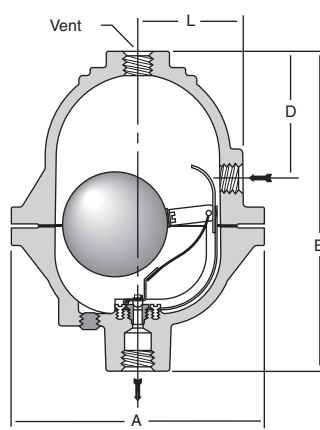

Figure LD-457-3.
Model 71-A cast iron snap action drain trap.

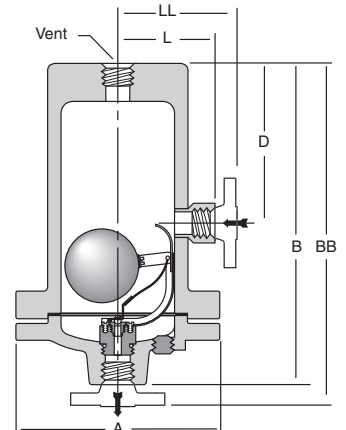

Figure LD-457-4.
Model 71-315 forged steel snap action drain trap.

Liquid Drainers

All dimensions and weights are approximate. Use certified print for exact dimensions. Design and materials are subject to change without notice.



High Leverage Spring-Loaded Ball Float Type Drain Traps

For Low Flows at Pressures to 255 bar and Specific Gravity Down to 0,40

The Armstrong High Leverage Series of liquid drain traps was developed especially for draining low specific gravity fluids from gases at high pressures. They use standard Armstrong forged steel bodies with very high leverage systems and spring assist.

Because of design considerations in this drain trap, it is essential that a safety factor of at least 2 be applied to the peak liquid load for sizing purposes.

Note: Models 2313-HLS, 2316-HLS, 2413-HLS and 2415-HLS are also available with cast T-316 stainless steel body and all-stainless steel internals. Consult factory.

Do not use HLS drain traps on steam service.

Sour Gas Service
 Forged steel and stainless steel traps can be modified to resist hydrogen sulfide stress corrosion. These modifications involve annealing the float, which will reduce the maximum working pressure of the float to about half its normal value. Consult Armstrong Application Engineering for allowable working pressures.

Model No.	Float Diameter	Unbalanced Float Weight
2313-HLS 2413-HLS 25133G-HLS	89 mm	113 g
2315-HLS 2415-HLS 25155G-HLS 26155G-HLS	102 mm	128 g
2316-HLS 2416-HLS	127 mm	170 g

Model No.	Sp. Grav.	1,00	0,95	0,90	0,85	0,80	0,75	0,70	0,65	0,60	0,55	0,50	0,45	0,40
		Maximum Operating Pressure in bar @ 38°C												
	Orifice (in)	bar	bar	bar	bar	bar	bar	bar	bar	bar	bar	bar	bar	bar
2313-HLS	1/16"	69	69	69	69	69	69	69	69	69	69	69	69	43
	5/64"	69	69	69	69	69	69	69	69	69	69	65	47	29
	3/32"	69	69	69	69	69	69	69	69	69	58	46	33	20
	7/64"	69	69	69	69	69	69	69	63	53	44	34	25	15
	1/8"	69	69	69	69	69	63	56	48	41	34	26	19	11,7
2315-HLS	3/32"	69	69	69	69	69	69	69	69	69	69	69	69	66
	1/8"	69	69	69	69	69	69	69	69	69	69	62	50	38
	5/32"	69	69	69	69	69	69	69	64	56	48	40	33	25
	3/16"	69	69	69	67	61	56	50	45	39	34	28	23	17
2316-HLS	3/32"	69	69	69	69	69	69	69	69	69	69	69	69	69
	1/8"	69	69	69	69	69	69	69	69	69	69	69	69	69
	5/32"	69	69	69	69	69	69	69	69	69	69	69	69	69
	3/16"	69	69	69	69	69	69	69	69	69	69	69	69	57
	7/32"	69	69	69	69	69	69	69	69	69	69	61	52	43
2413-HLS	1/16"	103	103	103	103	103	103	103	103	103	103	98	71	43
	5/64"	103	103	103	103	103	103	103	103	101	83	65	47	29
	3/32"	103	103	103	103	103	103	97	84	71	58	46	33	20
	7/64"	103	103	103	101	91	82	72	63	53	44	34	25	15
2415-HLS	3/32"	124	124	124	124	124	124	124	124	124	124	108	87	66
	1/8"	124	124	124	124	124	122	110	98	86	74	62	50	38
	5/32"	119	111	103	95	87	80	72	64	56	48	40	33	25
	3/16"	83	78	72	67	61	56	50	45	39	34	28	23	17
2416-HLS	3/32"	110	110	110	110	110	110	110	110	110	110	110	110	110
	1/8"	110	110	110	110	110	110	110	110	110	110	110	110	110
	5/32"	110	110	110	110	110	110	110	110	110	110	110	102	84
	3/16"	110	110	110	110	110	110	110	110	109	97	84	72	59
	7/32"	110	110	110	110	110	108	99	90	81	71	62	53	44
25133G-HLS	1/16"	146	146	146	146	146	146	146	146	146	125	98	71	43
	5/64"	146	146	146	146	146	146	137	119	101	83	65	47	29
	3/32"	146	146	146	135	122	110	97	84	71	58	46	33	20
	7/64"	129	120	110	101	91	82	72	63	53	44	34	25	15
25155G-HLS	5/64"	174	174	174	174	174	174	174	174	174	174	152	123	93
	3/32"	174	174	174	174	174	174	174	170	150	129	108	87	66
	1/8"	174	171	159	147	135	122	110	98	86	74	62	50	38
	5/32"	119	111	103	95	87	80	72	64	56	48	40	33	25
	3/16"	83	78	72	67	61	56	50	45	39	34	28	23	17
26155G-HLS	5/64"	255	255	255	255	255	255	255	241	211	182	152	123	93
	3/32"	255	255	255	254	233	212	191	170	150	129	108	87	66
	1/8"	183	171	159	147	135	122	110	98	86	74	62	50	38
	5/32"	119	111	103	95	87	80	72	64	56	48	40	33	25
	3/16"	83	78	72	67	61	56	50	45	39	34	28	23	17
Specific Gravity		1,00	0,95	0,90	0,85	0,80	0,75	0,70	0,65	0,60	0,55	0,50	0,45	0,40

Note: If actual specific gravity falls between those shown in above table, use next lower. For example, if actual gravity is 0,73, use 0,70 data.

Liquid Drainers

High Leverage Spring-Loaded Ball Float Type Drain Traps

For Low Flows at Pressures to 255 bar and Specific Gravity Down to 0,40



Table LD-459-1. HLS Series List of Materials					
Model No.	Valve & Seat	Leverage System	Float	Body & Cap	Gasket
2313-HLS 2315-HLS 2316-HLS	Stainless Steel			ASTM A105 Forged Steel	Compressed Asbestos-free
2413-HLS 2415-HLS 2416-HLS 25133G-HLS 25155G-HLS 26155G-HLS				ASTM A182 Grade F22 Forged Steel	

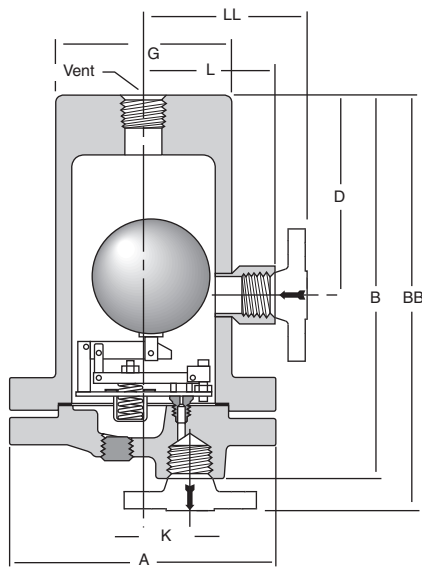

Figure LD-459-1.
High leverage ball float drain trap.

Table LD-459-2. HLS Series Physical Data in mm									
Model No.	2313-HLS †	2315-HLS	2316-HLS †	2413-HLS †	2415-HLS †	2416-HLS	25133G-HLS	25155G-HLS	26155G-HLS
Pipe Connections	15 – 20 – 25	25 – 32 – 40	40 – 50	15 – 20 – 25	25 – 32 – 40	40 – 50	15 – 20 – 25	20 – 25 – 32	25 – 32 – 40
"A"	203	248	302	219	273	318	216	263	298
"B"	295	381	435	305	379	448	362	412	613
"BB" (PN100 – 160 – 250*)	343 – 349 – 355	442 – 444 – 446	500 – 505	353 – 360 – 366	440 – 444 – 448	515 – 526	472 – 473 – 487	540 – 540 – 540	740 – 740
"D"	154	198	229	137	184	229	75	102	127
"G"	130	175	213	137	175	219	146	187	213
"K"	37	44	54	37	44	54	33	44	44
"L"	98	119	146	102	122	148	–	–	–
"LL" (PN100 – 160 – 250*)	145 – 153 – 159	171 – 173 – 175	198 – 204	149 – 156 – 162	181 – 183 – 187	211 – 244	185 – 187 – 190	214 – 214 – 214	224 – 224
Weight in kg (screwed & SW)	21	44	73	31	59	95	51	78	147
Weight in kg (PN100 – 160 – 250*)	23,0 – 25,0 – 26,0	46,0 – 50,0 – 53,0	84,2 – 88,2	35,0 – 37,0 – 38,0	60,6 – 64,6 – 67,6	104,0 – 108,0	56,0 – 57,0 – 58,0	101,0 – 102,0 – 103,0	154,2 – 160,2
Maximum Allowable Pressure (Vessel Design)	69 bar @ 38°C 41 bar @ 400°C			103 bar @ 38°C 62 bar @ 454°C	125 bar @ 38°C 62 bar @ 482°C	146 bar @ 38°C 117 bar @ 482°C	174 bar @ 38°C 138 bar @ 482°C	255 bar @ 38°C 207 bar @ 482°C	

Note: Available with screwed, socketweld or flanged connections.

† Available with cast 316 stainless steel body and all stainless steel internals. Consult factory.

* Other flange sizes, ratings and face-to-face dimensions are available on request.

All products are CE Marked according to the PED (97/23/EC).

All dimensions and weights are approximate. Use certified print for exact dimensions. Design and materials are subject to change without notice.



Free Floating Lever Dual Gravity Drain Traps

For Pressures to 69 bar

Armstrong free floating lever dual gravity drain traps are identical to the units described on pages LD-451 and LD-455 except float weights are modified to make them suitable for draining water from a light liquid. If you wish to use them for draining any liquid with specific gravity other than 1,00, consult the Armstrong Application Engineering Department.

Floats for dual gravity drain traps are weighted with quenching oil which, in the unlikely possibility of float failure, may be dispersed through the system. If this is a hazard, consult the Armstrong Application Engineering Department.

Note: Armstrong can design dual gravity traps for venting light liquids from above heavier liquids. Consult the Armstrong Application Engineering Department.

Viscosity Considerations for Dual Gravity Traps

The operation of dual gravity traps depends upon a float that will sink in the light liquid and float in the heavy liquid. When the specific gravities of the two liquids are very close, the available operating forces are, therefore, also very small. Viscous fluids may impair the ability of the trap to respond to changing liquid levels.

Consult Armstrong's Application Engineering Department if your application involves fluids more viscous than 70 cs, which is approximately the viscosity of a light machine oil.

Table LD-460-2. Maximum Operating Pressures in bar for Draining Water From Different Specific Gravity Liquids With Orifices Available in Dual Gravity Drain Traps (See pages LD-438 and LD-439)

Model No.	Sp. Grav.	0,50	0,55	0,60	0,65	0,70	0,75	0,80	0,85		
	Float Wt. g	170	184	199	213	228	242	257	271		
Orifice (in)		Maximum Operating Pressure in bar									
2-DG	5/16"	1,0	0,9	0,7	0,6	0,5	0,35	–	–		
	1/4"	1,6	1,4	1,2	1,0	0,8	0,6	0,4	–		
	3/16"	3,6	3,0	2,6	2,2	1,8	1,4	0,9	0,45		
	5/32"	6,0	5,5	4,6	3,8	3,0	2,4	1,6	0,8		
	1/8"	10,0	9,0	8,0	6,5	5,0	4,0	2,6	1,4		
	7/64"	13,0	12,0	10,0	8,5	6,5	5,0	3,4	1,8		
32-DG	Sp. Grav.	0,50	0,55	0,60	0,65	0,70	0,75	0,80	0,85		
	Float Wt. g	248	271	293	315	338	360	382	405		
	Orifice (in)		Maximum Operating Pressure in bar								
	5/16"	1,6	1,4	1,2	1,0	0,9	0,7	0,5	–		
	1/4"	2,6	2,4	2,0	1,8	1,4	1,2	0,8	0,5		
	3/16"	6,0	5,0	4,6	3,8	3,2	2,6	1,8	1,2		
3-DG to 17 bar* Cast Iron 33-DG for all pressures	Sp. Grav.	0,50	0,55	0,60	0,65	0,70	0,75	0,80	0,85	0,90	
	Float Wt. g	317	345	373	401	430	458	486	514	542	
	Orifice (in)		Maximum Operating Pressure in bar								
	1/2"	0,8	0,7	0,6	0,5	0,45	0,35	–	–	–	
	3/8"	1,8	1,6	1,4	1,2	0,9	0,7	0,5	–	–	
	5/16"	2,8	2,4	2,2	1,8	1,4	1,2	0,8	0,5	–	
	9/32"	3,6	3,2	2,8	2,4	2,0	1,6	1,0	0,6	–	
	1/4"	5,5	4,8	4,2	3,6	3,0	2,2	1,6	1,0	–	
	7/32"	8,0	7,0	6,0	5,0	4,2	3,2	2,4	1,4	0,45	
	3/16"	12,0	10,0	9,0	7,5	6,5	4,8	3,4	2,0	0,7	
5/32"	19,0	16,0	14,0	12,0	10,0	7,5	5,5	3,2	1,0		
1/8"	38,0	34,0	28,0	24,0	20,0	15,0	11,0	6,5	2,2		
7/64	48,0	42,0	36,0	32,0	26,0	20,0	14,0	8,5	2,8		
6-DG to 17 bar* Cast Iron 36-DG to 69 bar Steel	Sp. Grav.	0,50	0,55	0,60	0,65	0,70	0,75	0,80	0,85	0,90	
	Float Wt. g	1 483	1 622	1 760	1 899	2 038	2 177	2 316	2 455	2 594	
	Orifice (in)		Maximum Operating Pressure in bar								
	1 1/6"	0,9	0,8	0,7	0,6	0,5	0,4	–	–	–	
	7/8"	1,4	1,2	1,2	1,0	0,8	0,7	0,5	0,35	–	
	3/4"	2,2	1,8	1,6	1,4	1,2	1,0	0,7	0,5	–	
	5/8"	3,2	2,8	2,6	2,2	1,8	1,4	1,2	0,8	0,4	
	9/16"	4,2	3,8	3,4	2,8	2,4	2,0	1,4	1,0	0,5	
	1/2"	6,0	5,5	4,8	4,2	3,4	2,8	2,2	1,4	0,8	
	7/16"	9,0	8,0	7,0	6,0	5,0	4,0	3,0	2,0	1,2	
3/8"	14,0	12,0	11,0	9,5	8,0	6,5	4,8	3,2	1,8		
11/32"	18,0	16,0	14,0	12,0	10,0	8,5	6,5	4,4	2,4		
5/16"	24,0	22,0	19,0	16,0	13,0	11,0	8,0	5,5	3,0		
9/32"	32,0	28,0	24,0	20,0	18,0	14,0	11,0	7,5	4,0		
1/4"	46,0	40,0	36,0	30,0	26,0	20,0	16,0	11,0	6,0		
7/32"	65,0	55,0	50,0	44,0	36,0	30,0	22,0	15,0	8,5		
3/16"	69,0	69,0	69,0	69,0	60,0	48,0	36,0	24,0	14,0		

Note: If actual specific gravity falls between those shown in the above table, use the next higher gravity. For example, if actual gravity is 0,73, use 0,75 gravity data.
* For vessel pressures above 17 bar, always use steel drain traps.

Free Floating Lever Dual Gravity Drain Traps

For Pressures to 69 bar



Table LD-461-1. DG Series List of Materials					
Model No.	Valve & Seat	Leverage System	Float	Body & Cap	Gasket
2-DG 3-DG 6-DG	Stainless Steel			Cast Iron ASTM A48 Class 30	Compressed Asbestos-free
32-DG 33-DG 36-DG				Forged Steel ASTM A105	

For information on special materials, consult the Armstrong Application Engineering Department.

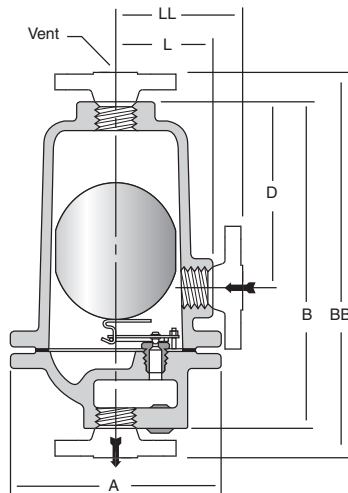

Figure LD-461-1.

Models 2-DG, 3-DG and 6-DG cast iron dual gravity drain traps.

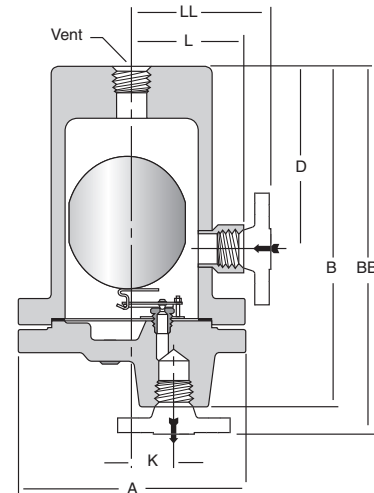

Figure LD-461-2.

Models 32-DG, 33-DG and 36-DG Forged steel dual gravity drain traps. Socketweld or flanged connections are also available.

Model No.	Cast Iron			Forged Steel		
	2-DG	3-DG	6-DG	32-DG*	33-DG*	36-DG*
Pipe Connections	15 – 20	15 – 20 – 25	40 – 50	15 – 20 – 25	15 – 20 – 25	40 – 50
"A"	133	161	259	171	203	302
"B"	203	273	432	259	295	435
"BB" (PN40 - PN100**)	320 – 330	400 – 392	562 – 568	300 – 305	343 – 349 – 355	500 – 505
"D"	111	155	213	141	154	229
"K"	–	–	–	32	37	54
"LL" (PN40 - PN100**)	179 – 189	203 – 195	180 – 186	127 – 132	145 – 153 – 159	198 – 204
"B"	203	273	432	259	295	435
Weight in kg (screwed & SW)	6	10	36	14	22	74
Weight in kg (flanged PN40 - PN100**)	8,7 – 9,6	13,6 – 14,2	42,6 – 45,0	15,8 – 17,8	25,0 – 26,0	83,2 – 87,2
Maximum Allowable Pressure (Vessel Design)	17 bar @ 232°C		17 bar @ 232°C	41 bar @ 38°C 35 bar @ 400°C	69 bar @ 38°C 41 bar @ 400°C	

* Available in Type 316 stainless steel. Consult factory.

** Other flange sizes, ratings and face-to-face dimensions are available on request.

Shade indicates products that are CE Marked according to the PED (97/23/EC). All the other models comply with the Article 3.3 of the same directive.

All dimensions and weights are approximate. Use certified print for exact dimensions. Design and materials are subject to change without notice.



Ultra-Capacity Drain Traps

Capacities to 317 500 kg/h... Pressures to 31 bar

Armstrong ultra-capacity ball float drain traps are designed to meet exceptionally large capacity needs in draining water and other liquids from air or other gases under pressure.

Options. L and M Series drain traps are available with armored gauge glass with a maximum allowable pressure of 17 bar @ 218°C. When ordering, be sure to specify "Liquid Drainer" or "LD." Example, LS-series LD, 50 mm BSPT, 7/8" orifice.

Model No.	Specific Gravity Orifice Size in	1,00	0,95	0,90	0,85	0,80	0,75	0,70	0,65	0,60	0,55	0,50
		Maximum Operating Pressure in bar										
JD	1 1/8"	1,0	1,0	0,89	0,82	0,75	0,69	0,62	0,48	0,41	0,34	0,28
	3/4"	2,4	2,2	2,0	1,8	1,6	1,5	1,3	1,0	0,97	0,75	0,62
	9/16"	6,0	5,5	5,0	4,6	4,2	3,8	3,3	2,8	2,4	1,8	1,5
	1/2"	10,0	9,0	8,5	8,0	7,0	6,2	5,5	4,8	4,0	3,2	2,6
	7/16"	12,0	12,0	12,0	12,0	11,0	10,0	8,5	7,3	6,2	5,0	3,9
	3/8"	17,0	16,0	15,0	13,0	12,2	10,9	9,7	8,4	7,1	5,9	4,6
	1/4"	21,0	21,0	21,0	21,0	20,7	20,7	20,7	20,7	18,8	15,4	12,1
30KD	1 7/8" dual orifice	2	2	2	2	-	-	-	-	-	-	-
50KD		3,5	3,5	3,5	3,5	-	-	-	-	-	-	-
300KD		21	21	21	21	-	-	-	-	-	-	-
L to 17 bar	1 5/8"	2,4	2,2	2,0	1,8	1,6	1,6	1,4	1,2	1,0	0,89	0,69
	1 1/8"	8,0	7,4	7,0	6,3	5,8	5,2	4,7	4,1	3,6	3,0	2,5
LS	7/8"	12,0	11,0	10,5	9,5	8,6	7,9	7,0	6,2	5,4	4,5	3,7
For all Pressures	11/16"	22,0*	20,0*	19,0*	17,0	16,0	14,0	13,0	11,0	9,7	8,2	6,7
	1/2"	31,0*	31,0*	31,0*	31,0*	31,0*	28,0*	24,0*	21,0*	17,0	14,0	10,0
M to 17 bar	1 7/8" dual orifice	17,0	17,0	17,0	17,0	-	-	-	-	-	-	-
MS For all Pressures	1 17/32" dual orifice	31,0*	31,0*	31,0*	31,0*	31,0*	-	-	-	-	-	-

* These pressures applicable only to "LS" and "MS" models.

Name of Part	Material	
	Series JD, KD, L & M	Series LS & MS
Cap & Body	JD, KD: ASTM A395 Ductil Iron L, M: ASTM A48 Class 30	ASTM A216 Grade WCB
Cap	L, LS: 304 Stainless Steel, ASTM A351 Grade CF8	
Extension*	K, M, MS: 17-4 Ph, ASTM A747 Grade CB7Cu-1	
Cap Bolting	ASTM A193 Grade B 7**	ASTM A193 Grade B 7
Cap Gaskets	Compressed Asbestos Free	
Float Mechanism	Stainless Steel	

* JD Series does not have cap extension.

** JD and KD Series - ASTM A307 Grade B.

Model	Size in mm	NPT	BSPT	SW	Flanged
JD	50	X	X	-	X
KD	50, 65, 80	X	X	-	X
L	50 - 65	X	X	-	X
M	80	X	X	-	X
LS	50 - 65	X	X	X	X
MS	80	X	X	X	X

Shade indicates products that are CE Marked according to the PED (97/23/EC). All the other models comply with the Article 3.3 of the same directive, but for "L" and "M" Series PMA is 11 bar.

Trap Series	JD & KD	L & M	LS & MS
Pipe Connections	50 - 65	50 - 65 - 80	50 - 65 - 80
"B"	332	514	508
"C"	246	375	387
"H"	348 - 373	505	508
"HH1" (PN40*)	420 - 448	574 - 580 - 585	571 - 575 - 581
"HH2" (PN40*)	420 - 548	-	-
"M"	152	287	287
"D"	75 - 90	106	106
"S"	-	95	95
"T"	-	305	305
Weight in kg (screwed & SW)	36,3 - 39,5	89	132
Weight in kg (flanged PN40*)	45 - 49	97 - 99 - 101	138 - 141 - 144
Maximum Allowable Pressure (Vessel Design)	21 bar @ 343°C	17 bar @ 232°C	31 bar @ 338°C
Maximum Operating Pressure	12 bar	17 bar	31 bar

* Other flange sizes, ratings and face-to-face dimensions are available on request.

JD, KD, L and M Series also may be used for steam service as float & thermostatic traps and as condensate controllers. Steam service capacities for all configurations are given in the steam trap section of this catalog.

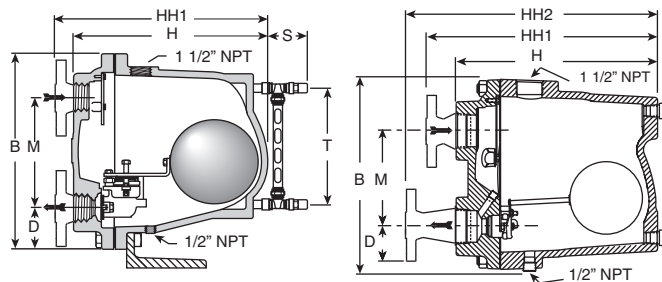

Figure LD-462-1. L and LS Series

Figure LD-462-2. JD and KD Series

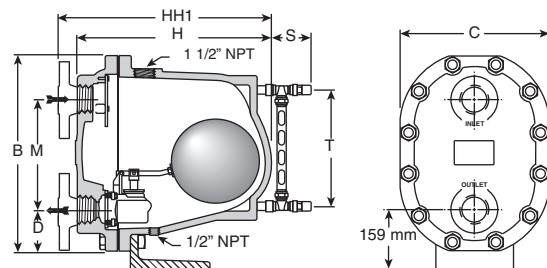

Figure LD-462-3. M and MS Series

All dimensions and weights are approximate. Use certified print for exact dimensions. Design and materials are subject to change without notice.